



Front Doors

RD40



“Ryterna Entry” is a part of the “Ryterna Group” who have been manufacturing doors since 1993. With authorised dealers all over Europe and our own transport fleet we can provide the shortest possible lead times. “Ryterna” entrance doors are manufactured in a new efficient factory located in Kaunas, Lithuania. Sustainability in manufacture combined with the thermal performance of our products is central to our growth philosophy. We constantly seek for morally responsible and environmentally cleaner ways to improve in all areas of business.

www.ryternaentry.com
www.ryternaentry.doorconfigurator.com



- Doors are made to measure:
 - STD:** 890 x 1990 **On request:** Width 700 ÷ 1150
 - 890 x 2090 Height 1700 ÷ 2250
 - 990 x 1990
 - 990 x 2090
- Double galvanized steel skin filled with PU foam door leaf
- Double sealing
- Tested at 200 000 open-close cycles

Thermal transmittance U value		1.3 W/m²K*
Air permeability		2
Water tightness		4A
Resistance to wind load, test pressure		3
Resistance to wind load, frame deflection		C

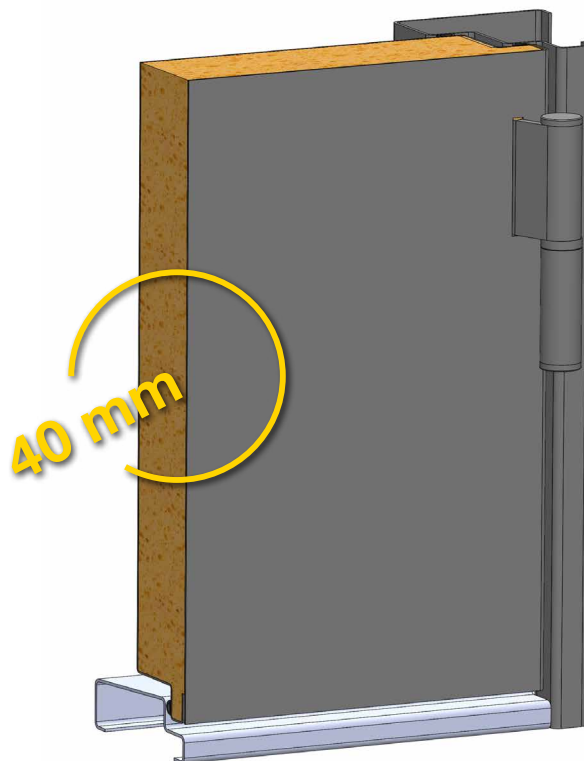

All doors are factory framed.
 Prices are for full door-sets.
 All dimensions are specified for overall frame sizes.
 Depicted images are for illustration only. Actual product may vary due to constant enhancement.
 Ryterna reserves right to change specifications at any time and without prior warning.

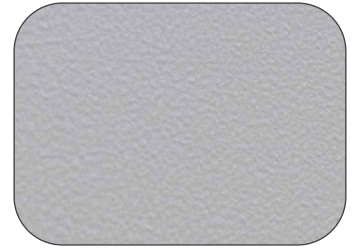

Structure painting (STR)

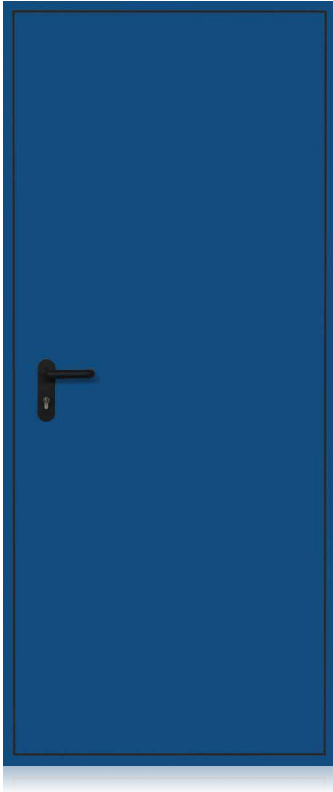

RAL 5010 STR



RAL 7016 STR



RAL 8017 STR



RAL 9002 STR



RAL 9006 STR

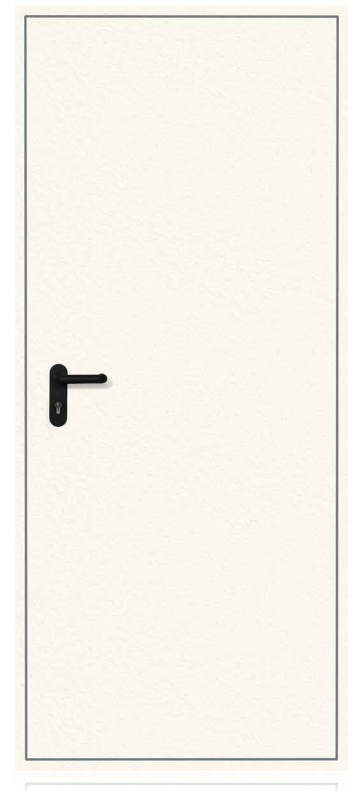

RAL 9016 STR



Model **RD40**
Outside colour **RAL 9006 STR**
Handle **Black (BL)**
Lock **STD**

- Entrance doors are made of 1 mm galvanized steel skin filled with PU that forms firm and durable construction.

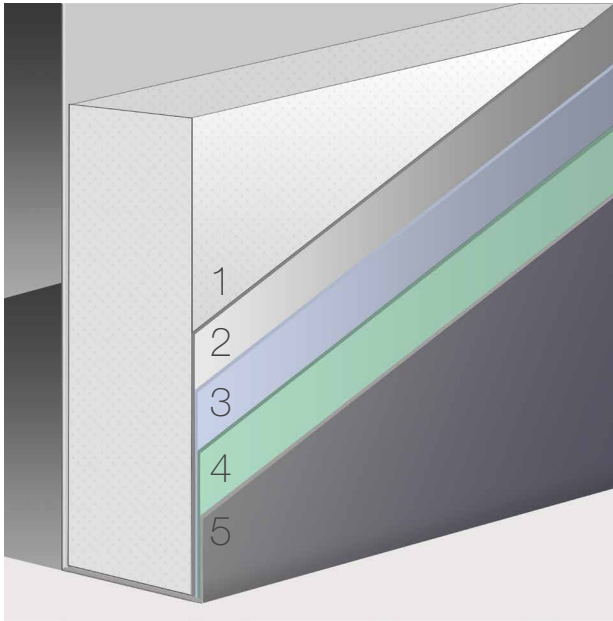

Door Leaf Structure

- 1** Polyurethane foam
- 2** Cold rolled steel
- 3** Hot dip galvanisation
- 4** Chemical treatment
- 5** Powder paint

U-value up to
1,3 W/M²K

- 6 **STD** RAL STRUCTURE colours.
Painting available upon request.
Only structure painting.



- Corrosion protected 1 mm skins linked together, with 40mm PU insulation and forms solid "sandwich panel".

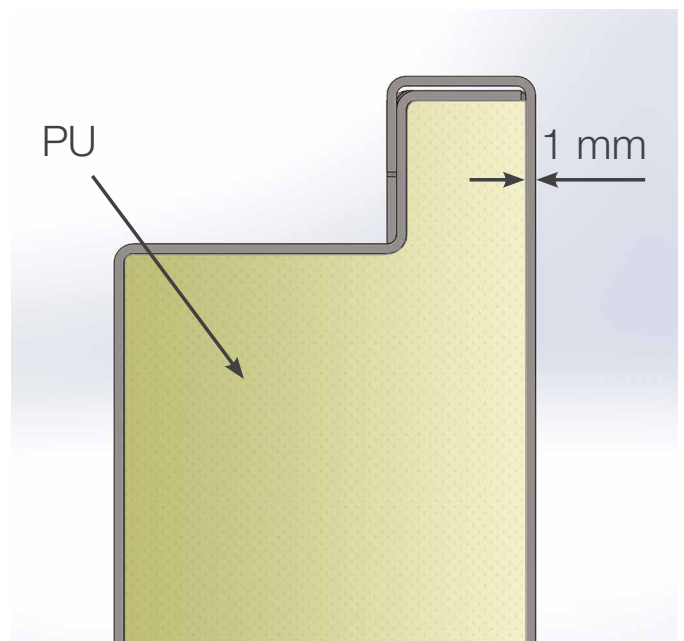

- Double sealing around all the perimeter provides excellent thermal insulation and water resistance.

Door frame made of 1.5 mm thickness galvanized steel

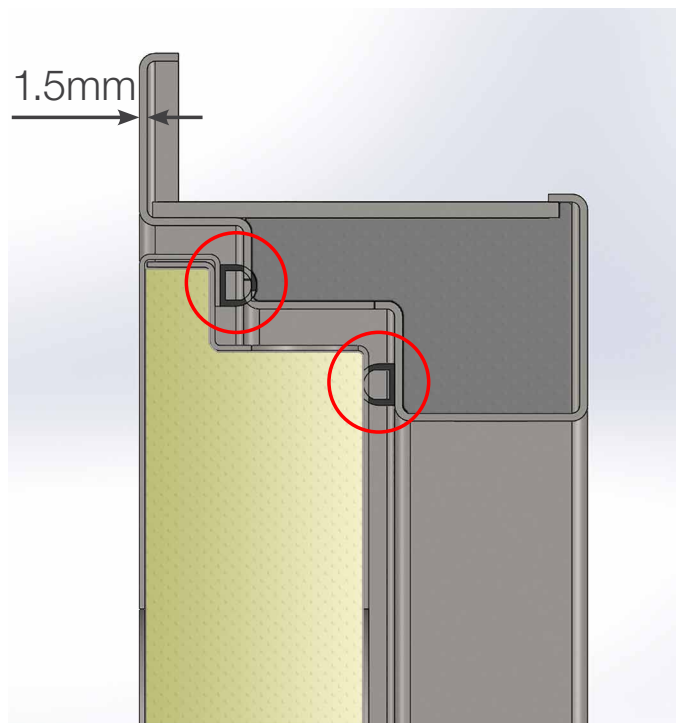

- 3 pcs, adjustable hinges with bearing ensure long – life, smooth and quiet operation.

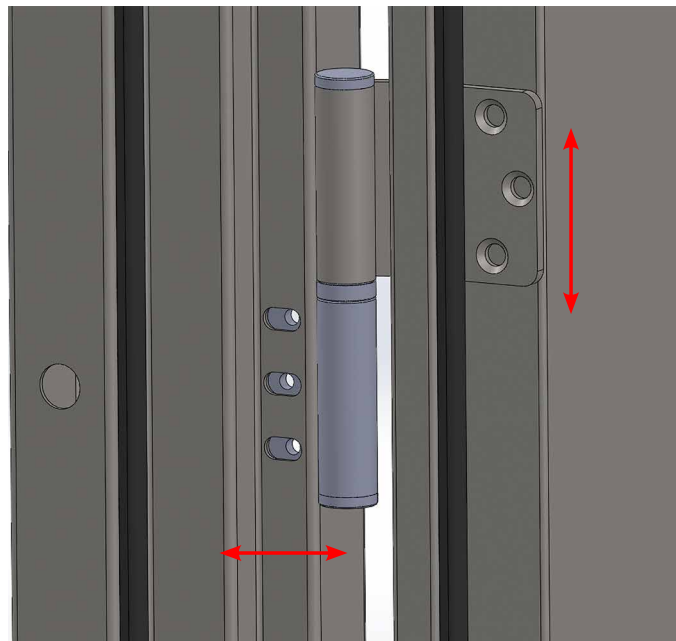

MITRED FRAME WITH MOULDINGS, OPEN TO OUTSIDE (MO)

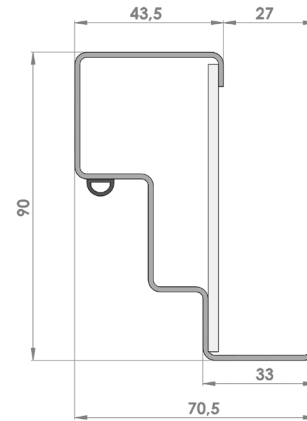
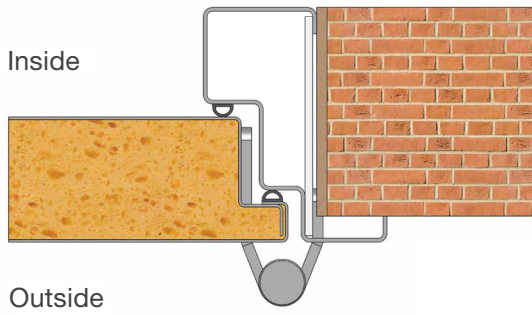

MITRED FRAME, OPEN TO OUTSIDE (LO)

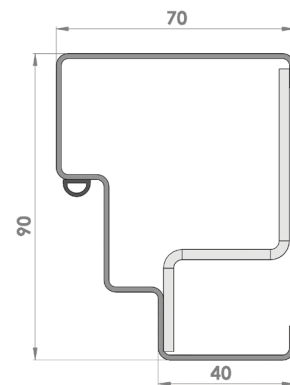
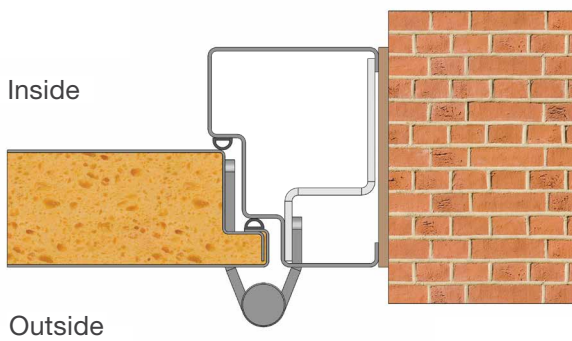

MITRED FRAME WITH MOULDINGS, OPEN TO INSIDE (MI)

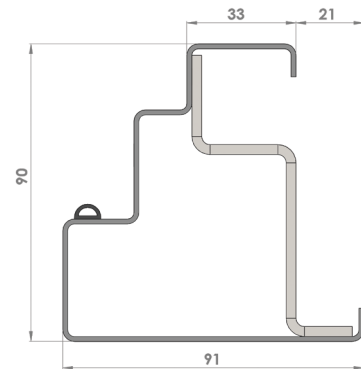
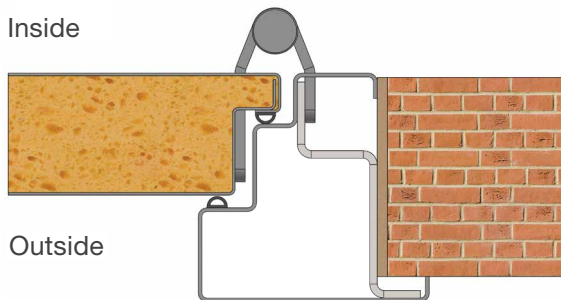

MITRED FRAME, OPEN TO INSIDE (LI)

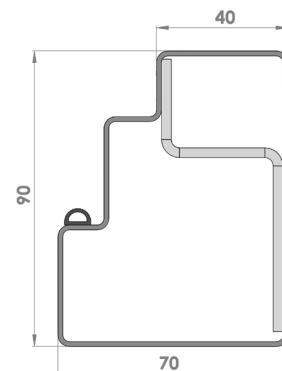
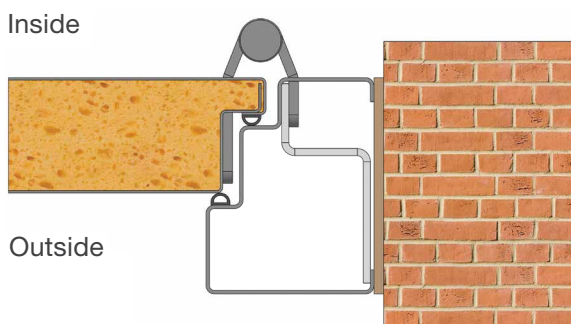

DOUBLE SEALING THRESHOLD, OPEN TO OUTSIDE (OD)

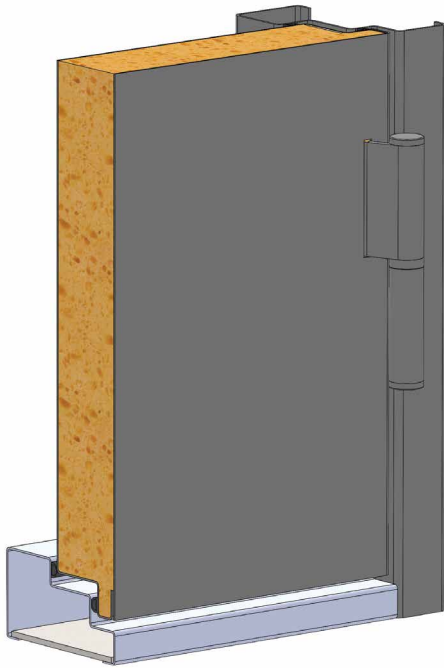

MO-OD

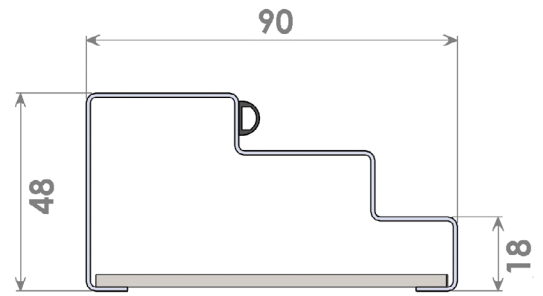
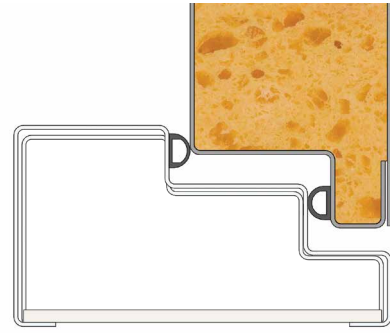

Inside

Outside

OFS & DAYLIGHT OPENING

MO frame

Outside

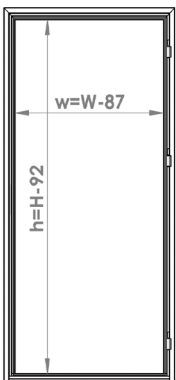

Inside W

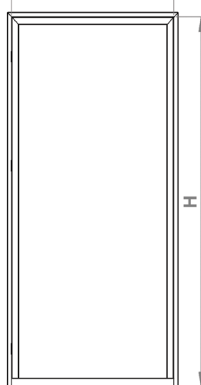

LO frame

Outside W

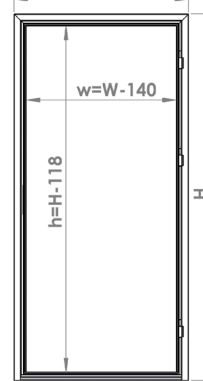

Inside W

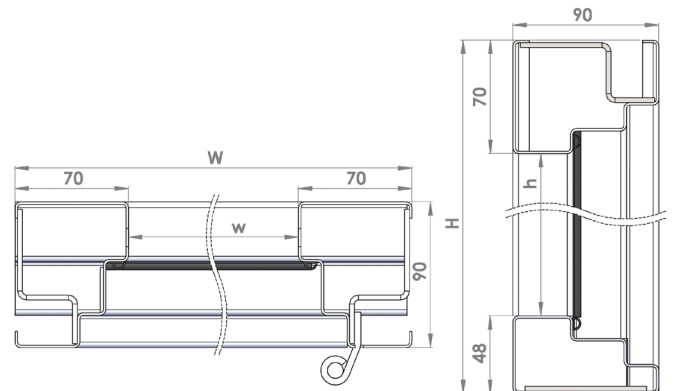
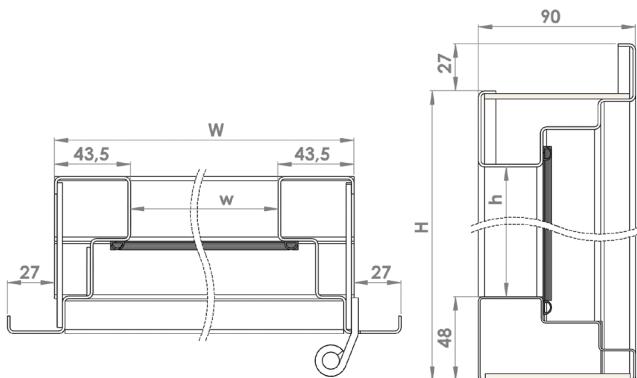
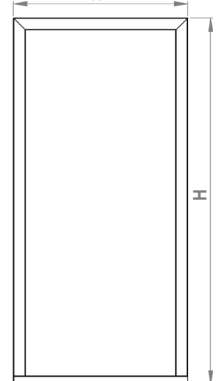

SINGLE SEALING THRESHOLD, OPEN TO OUTSIDE (OS)

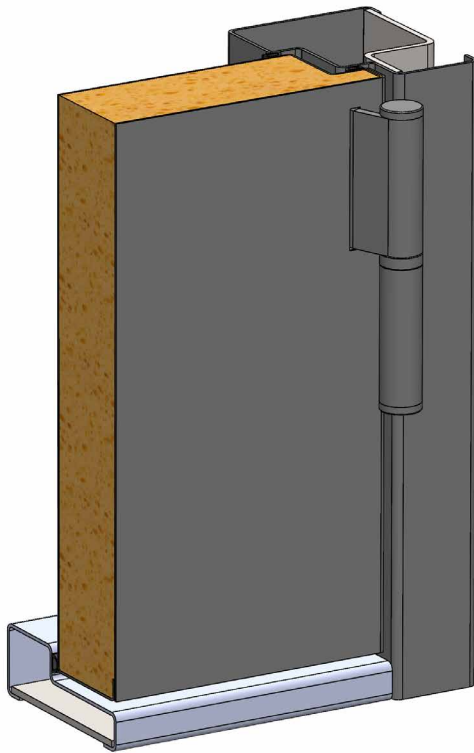

LO-OS

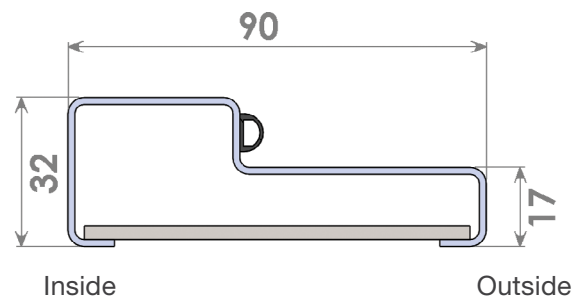
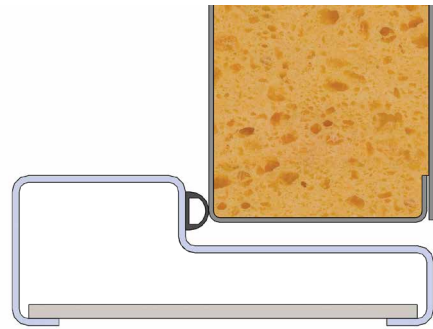

OFS & DAYLIGHT OPENING

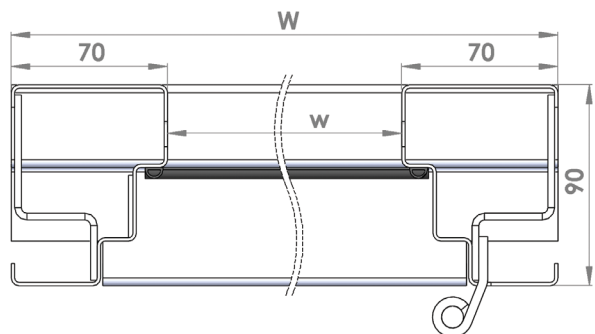
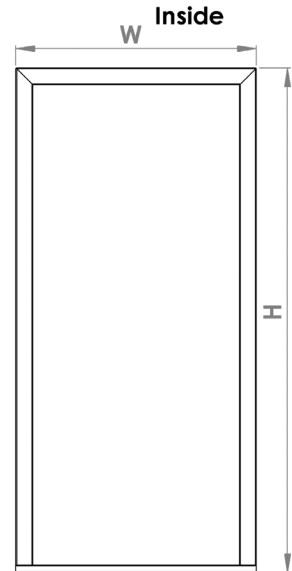
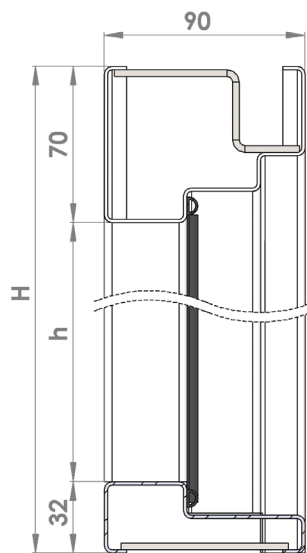
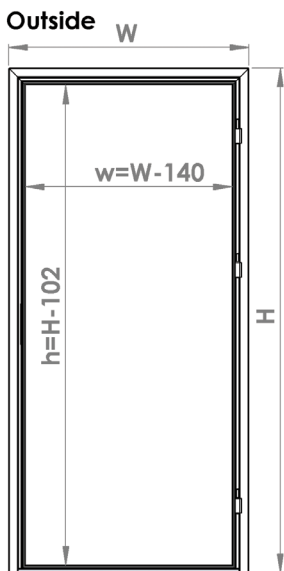

SINGLE SEALING THRESHOLD, OPEN TO OUTSIDE (OS2)

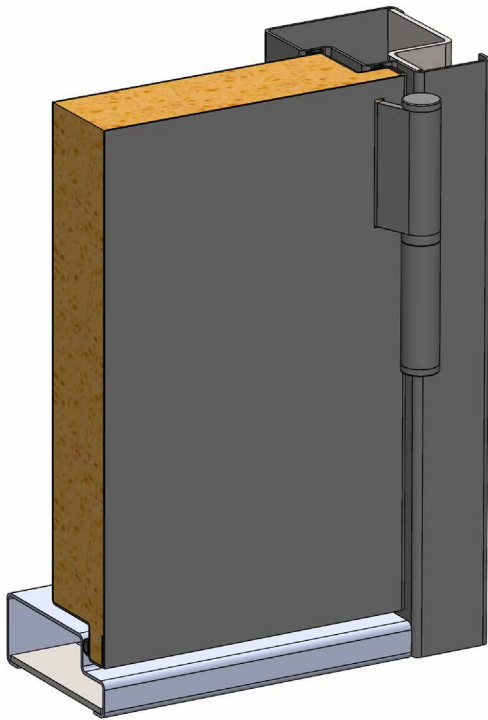

LO-OS2

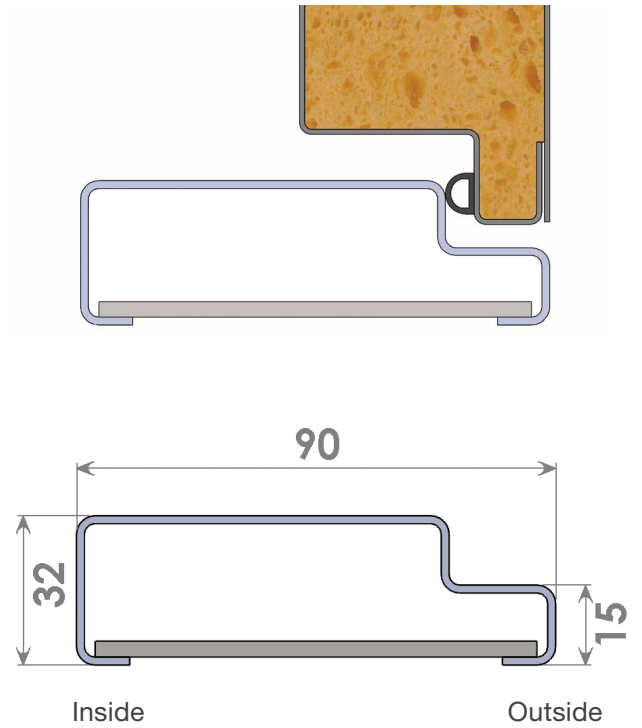

OFS & DAYLIGHT OPENING

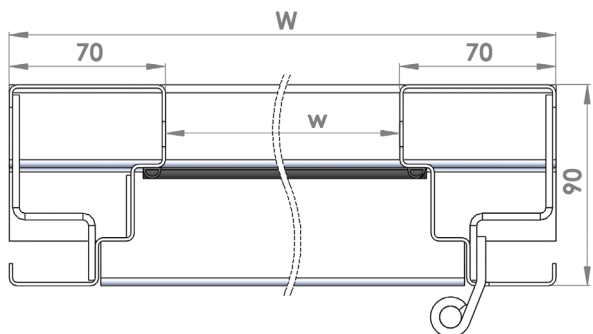
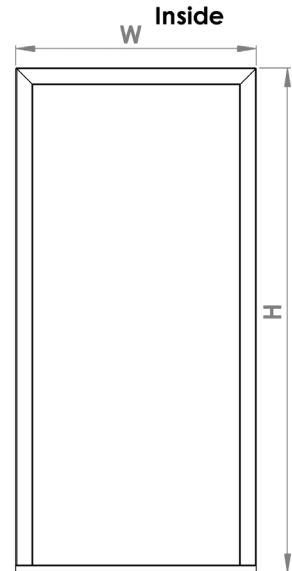
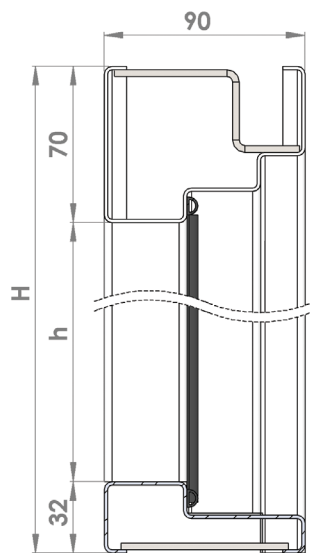
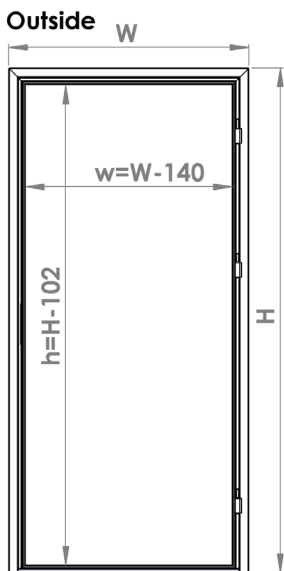

MITRED FRAME WITH MOULDINGS, OPEN TO OUTSIDE (OM)

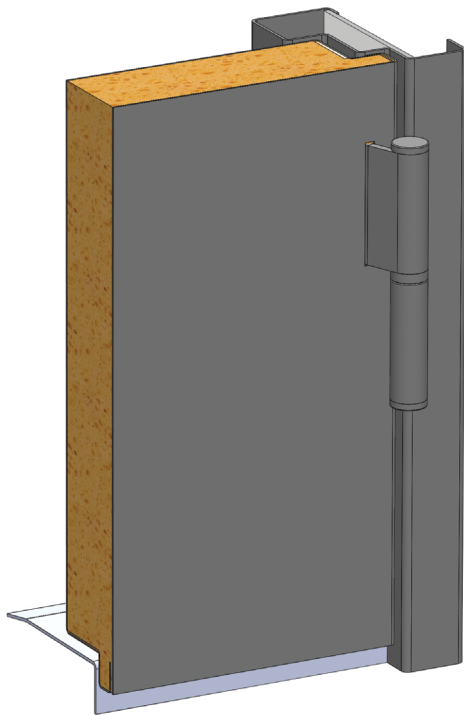

MO-OM

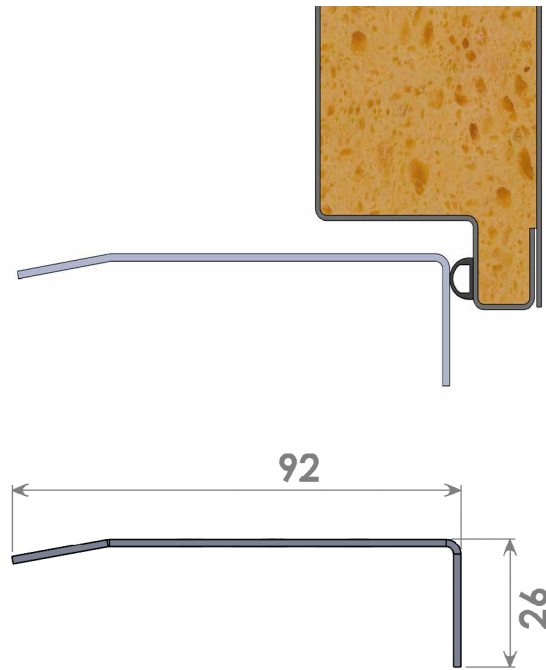

Inside

Outside

OFS & DAYLIGHT OPENING

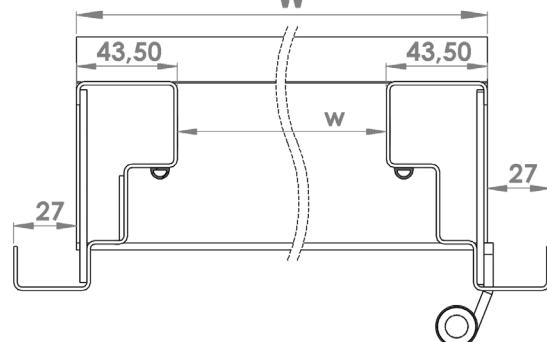
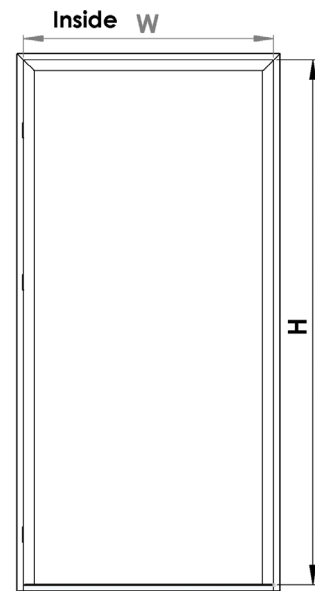
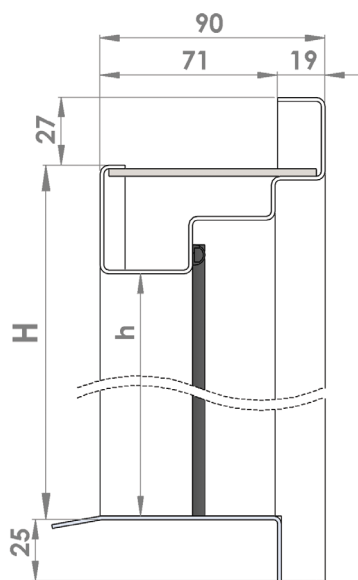
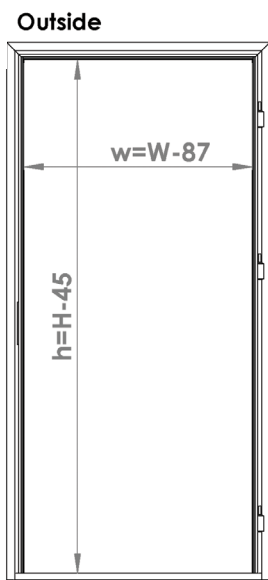

WITHOUT THRESHOLD, OPEN TO OUTSIDE (OW)

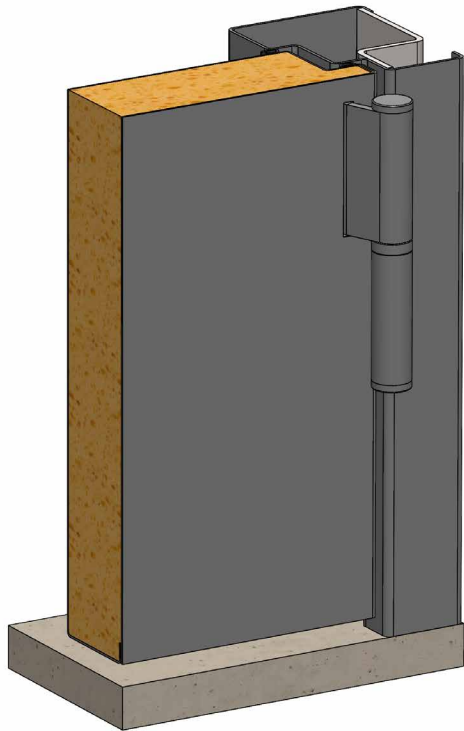

LO-OW

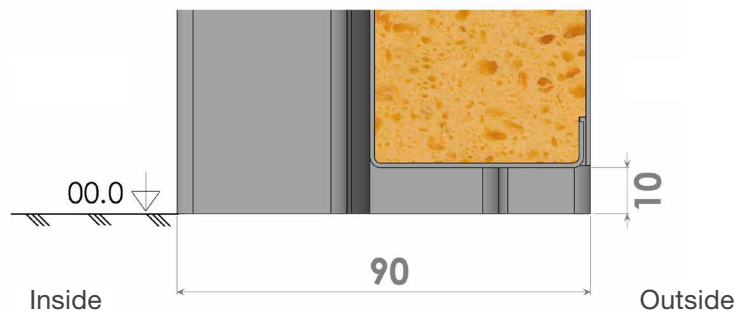
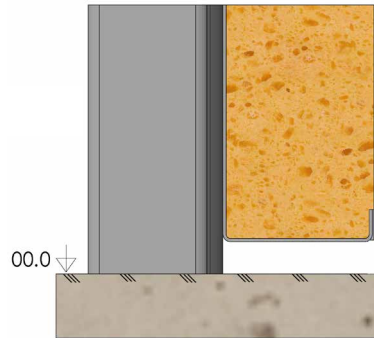

OFS & DAYLIGHT OPENING

MO frame

LO frame

Outside

Inside W

Outside W

Inside W

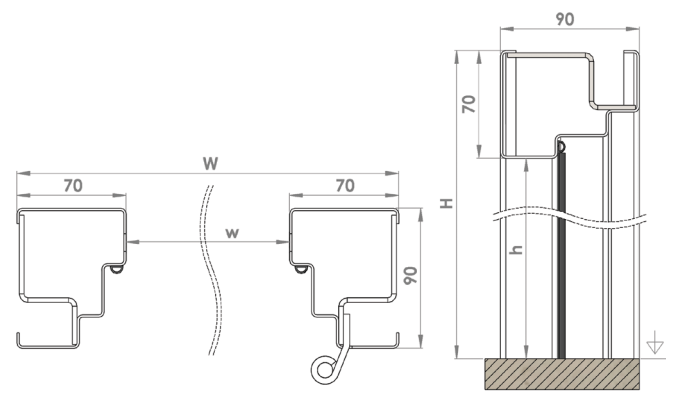
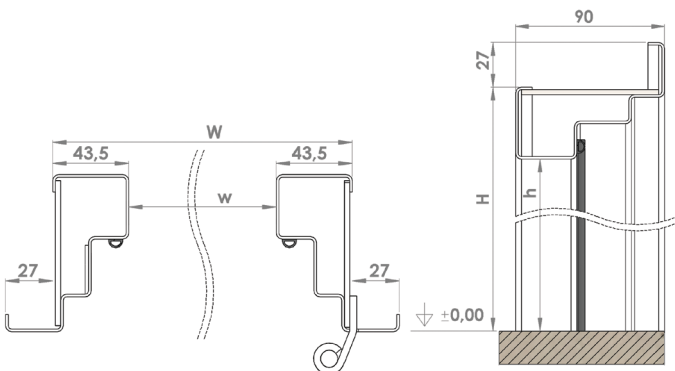
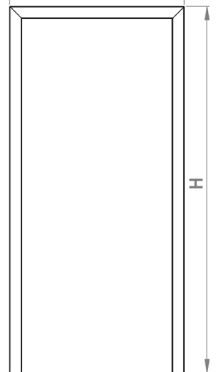
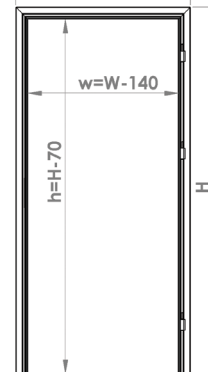
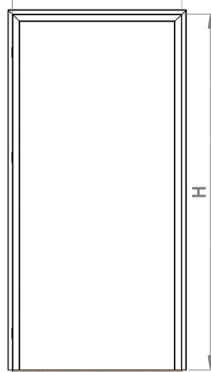
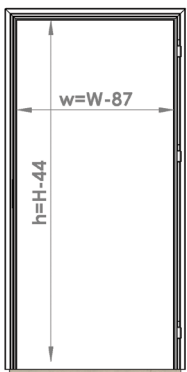

SINGLE SEALING ANGLED THRESHOLD, OPEN TO INSIDE (IS)

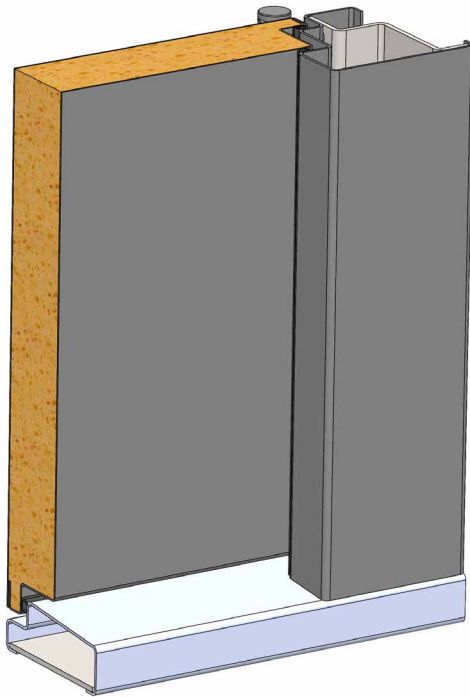

LI-IS

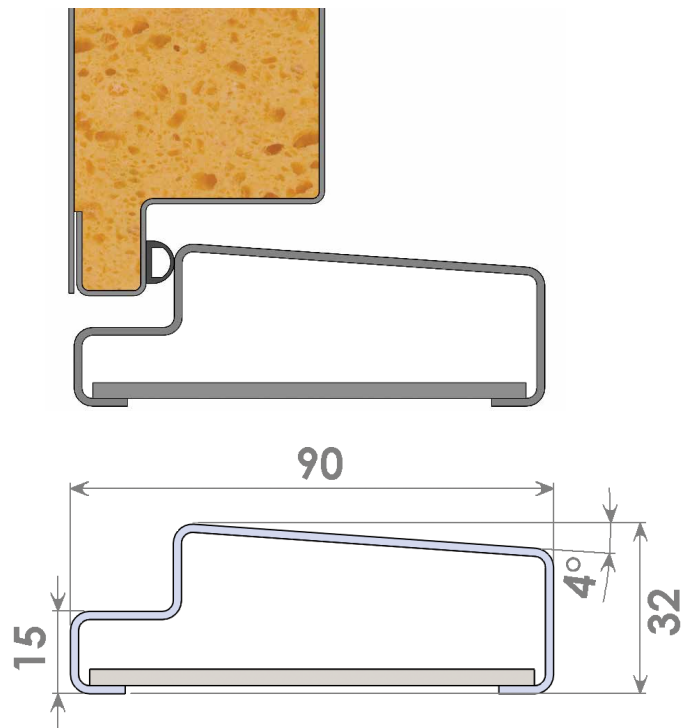

Inside

Outside

OFS & DAYLIGHT OPENING

MI frame

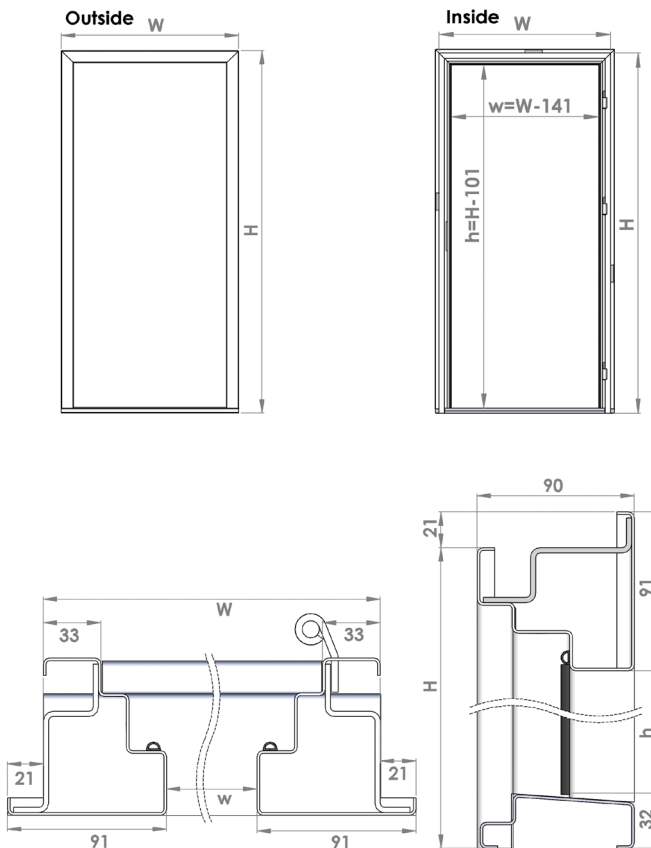

LI frame

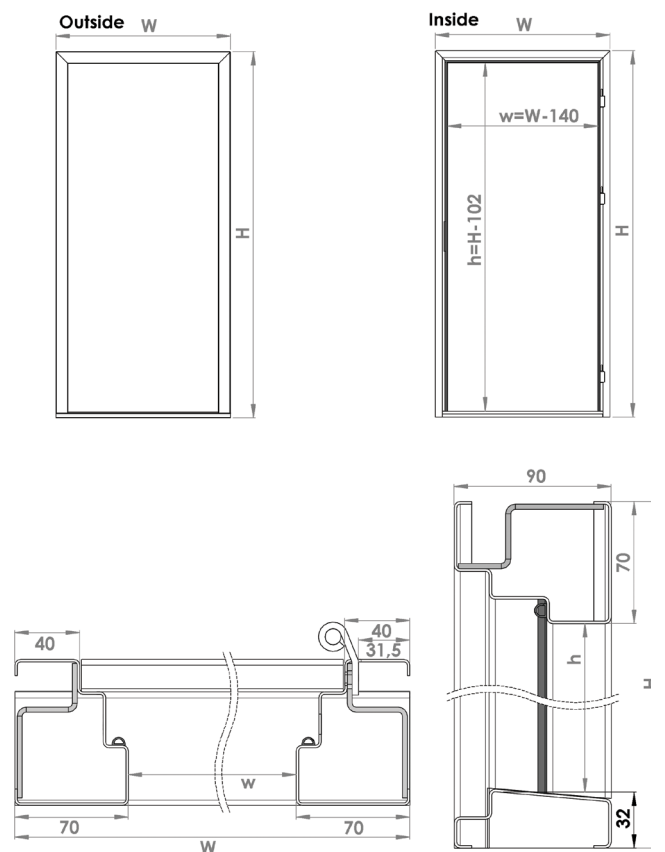

WITHOUT THRESHOLD, OPEN TO INSIDE (IW)

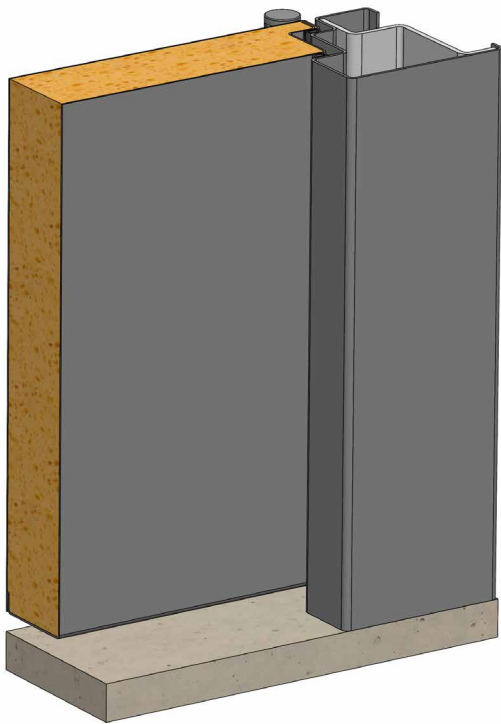

LI-IW

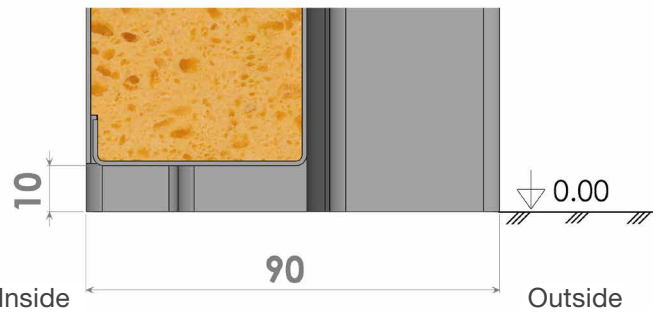
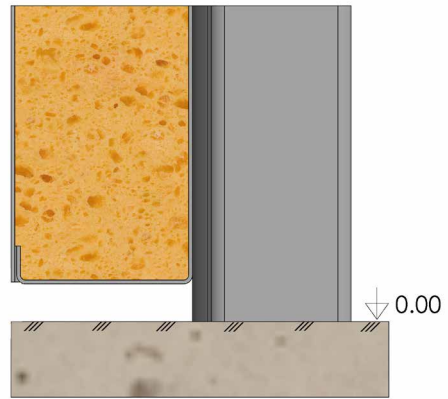

OFS & DAYLIGHT OPENING

MI frame

LI frame

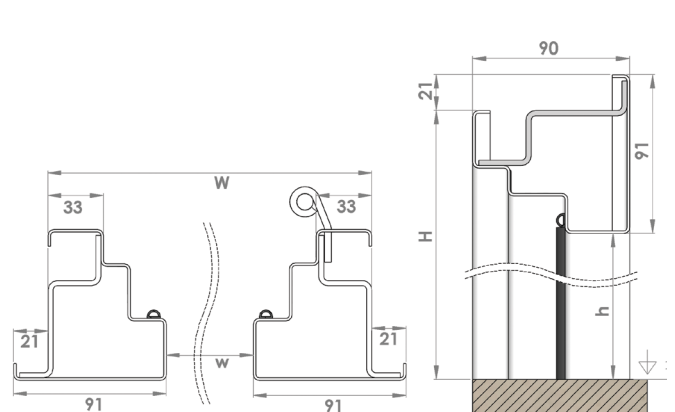
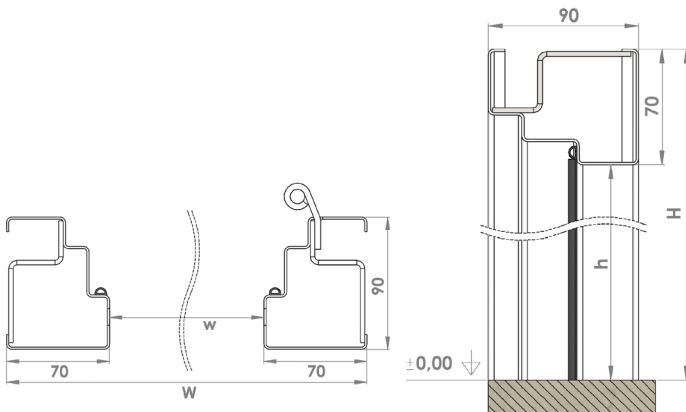
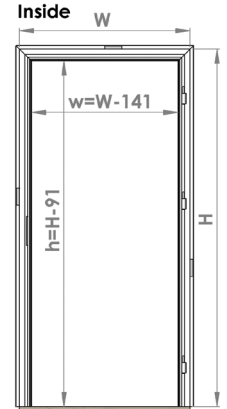
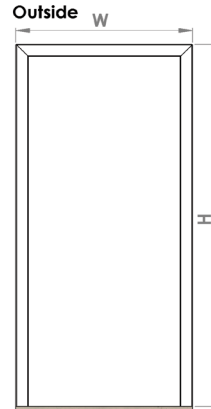
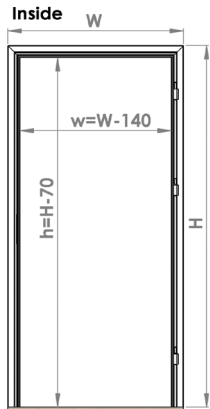
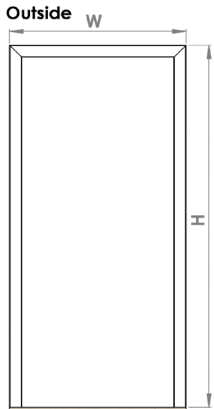

MO OPEN LEAF 90°

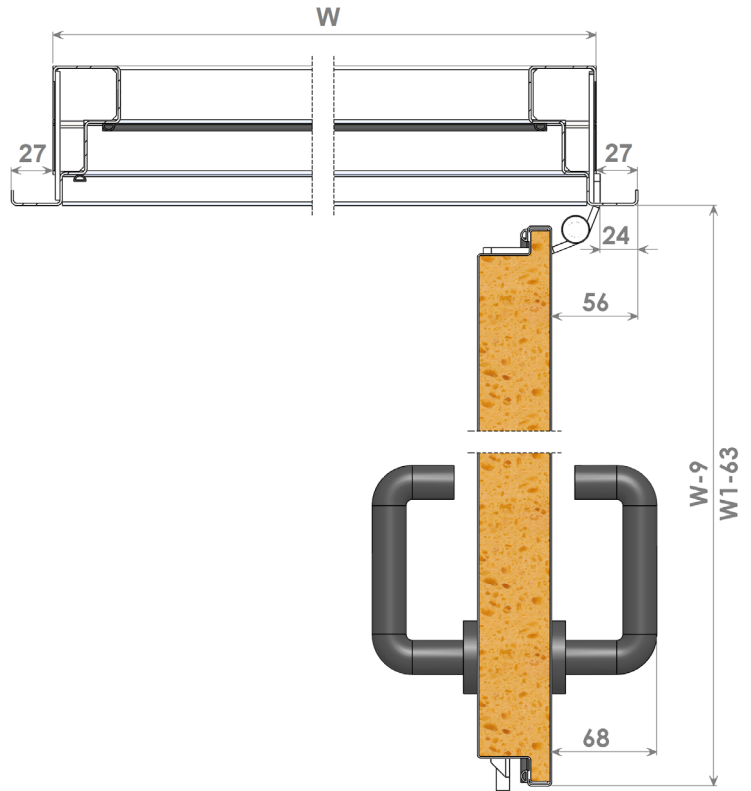
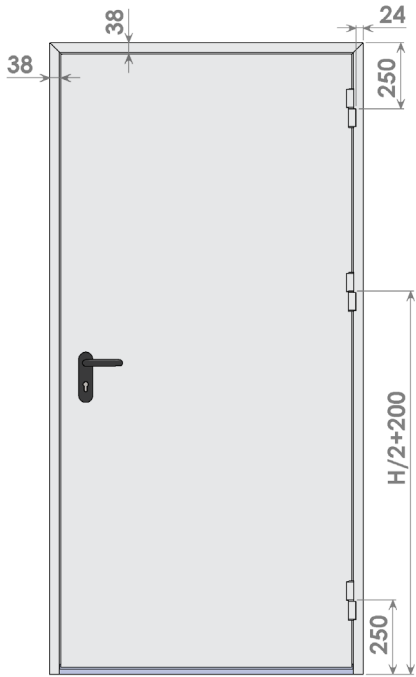

LO OPEN LEAF 90°

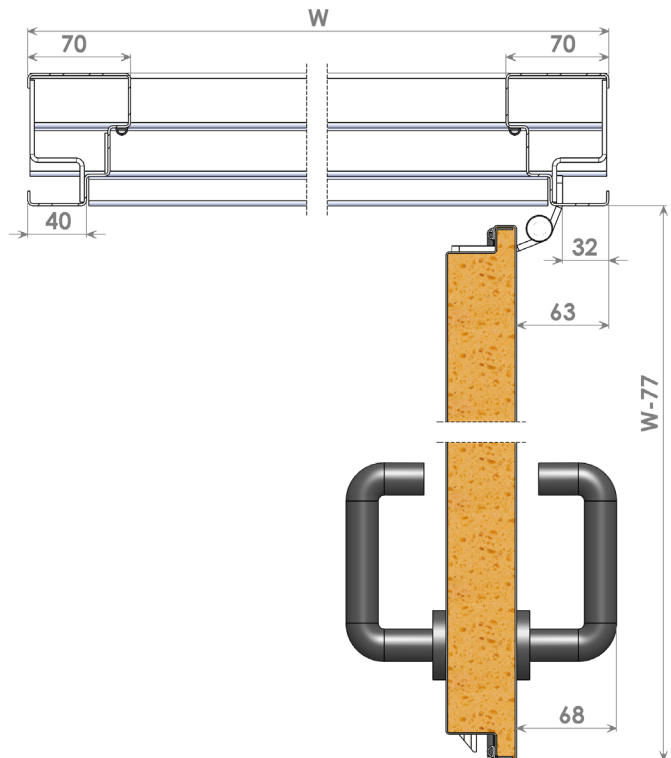
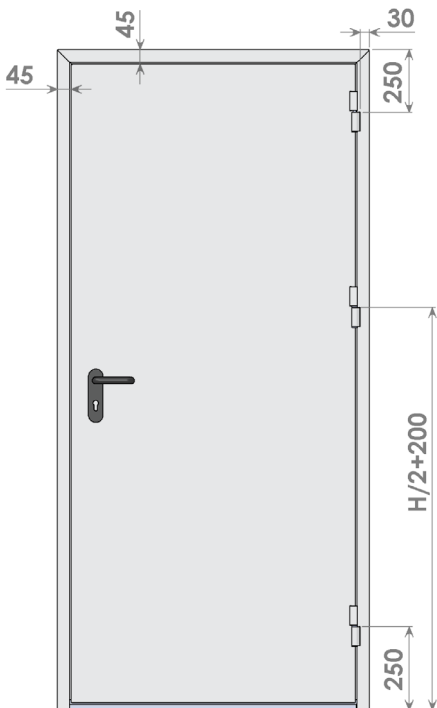

LOCKS AND HANDLES



L1P
Lock
STD



BL
Black lever handle
STD



GR
Grey lever handle
STD



ST
Stainless steel
lever handle



SSK
Stainless steel
knob handle



CWD
Lock cylinder
STD



LC 100
Lock



565
Lock



AS
Lever handle



CWE
Lock cylinder

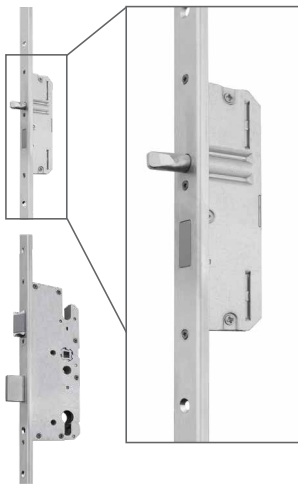

C3P
Multi-point lock

D&N+EM



HL
White
lever handle



HK
White
knob handle



HLA
Aluminium
lever handle



CWF
Lock cylinder



APL
Lock



SSK
Stainless steel
knob handle



APLH
Anti-panic
handle



CWAP
Lock cylinder

GLAZING



S200

Square glazing
200x200 mm



S350

Square glazing
350x350 mm

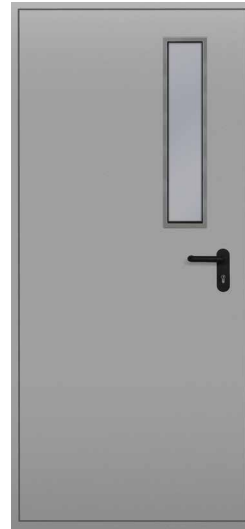

S100

Rectangular glazing
100x700 mm



S500

Rectangular glazing
500x700 mm

ACCESSORIES

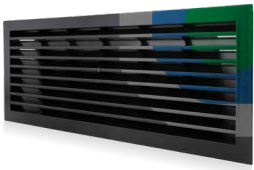

Ventilation grille



Spyhole



Door closer



PL201
Padlock staple



KP1
Keypad



Release date:
01.01.2024

