

TECHNICAL DATA

Industrial doors

CONTENT

4 TRACKS

- 5.....STD
- 6.....LHR-FM
- 7.....LHR-RM
- 8.....STD-RM
- 9.....HL-TM
- 10.....VL-TM
- 11.....HL-MM1 with lower torsion spring shaft
- 12.....HL-MM2 with lower torsion spring shaft
- 13.....VL-MM1 with lower torsion spring shaft
- 14.....VL-MM2 with lower torsion spring shaft
- 15.....STD-PR
- 16.....RM-PR
- 17.....FM-PR
- 18.....HL-TM PR
- 19.....TLP 80 THERMO panels / tracks
- 20.....INDUSTRIAL SSD (side sliding sectional door)
- 21.....SFD (side framed door)

22 PANELS

- 23.....PANEL TYPES
- 25.....ALU-framed PANEL TYPES
- 28.....Reinforcement profiles ≤ 8000
- 29.....Reinforcement profiles > 8000
- 30.....Reinforcement profiles on glazed panels

31 WINDOWS

- 32.....Types of windows

33 WICKET DOOR

- 34.....WICKET DOOR

36 THRESHOLD TYPES

- 37.....STANDARD THRESHOLD
- 38.....LOW THRESHOLD

39 SIDE-HINGED DOORS

- 40.....SIDE DOOR (SH1)
- 43.....DOUBLE HINGED DOOR (SH2)

45 OPERATORS

- 46.....OPERATORS' FIXING OPTIONS

TRACKS



STD

Required sideroom	SL	SR
Manual operation	110	110
Electric motor on shaft	110	220-320
Chain host	110	220-320

Number or required suspensions	
Up to depth of 3500 mm	2 suspensions per side
Up to depth of 4500 mm	3 suspensions per side
Up to depth of 5500 mm	4 suspensions per side
Above depth of 5500 mm	5 suspensions per side

Required headroom	h	D	Opening
$H \leq 4200$	370	$H + 510$	H
$4200 < H \leq 5030$	430	$H + 510$	H
$5030 < H \leq 6000$	505	$H + 510$	H
$H > 6000$ on request			

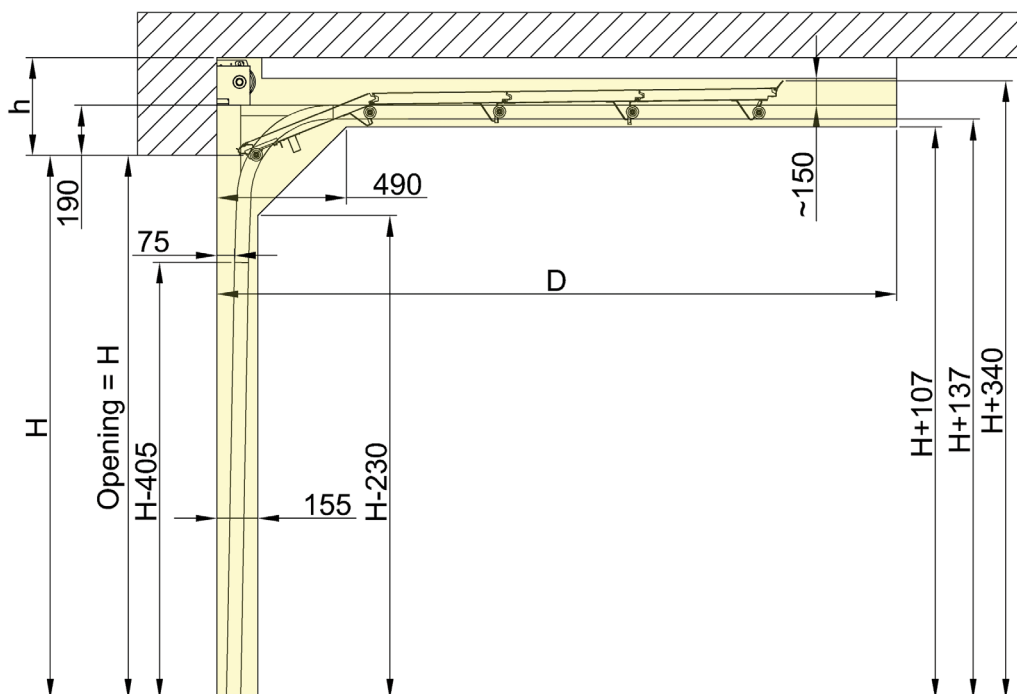

3

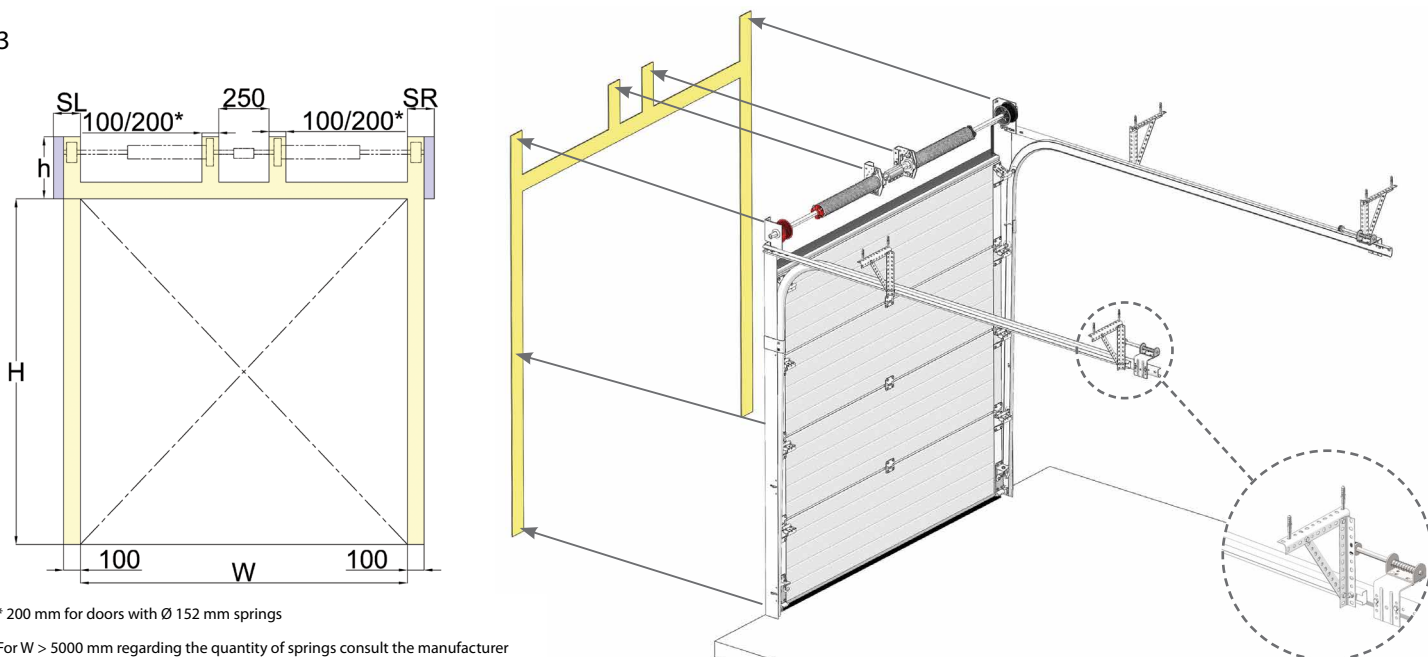

* 200 mm for doors with $\varnothing 152$ mm springs

For $W > 5000$ mm regarding the quantity of springs consult the manufacturer

LHR-FM

Required sideroom	SL	SR
Manual operation	110	110
Electric motor on shaft	110	220-320
Chain host	110	220-320

Required headroom	h	D	Opening
$H \leq 4200$	270	$H + 510$	$H - 130$
$4200 < H \leq 5030$	310	$H + 510$	$H - 130$
$H > 5030$ on request			

Number or required suspensions	
Up to depth of 3500 mm	2 suspensions per side
Up to depth of 4500 mm	3 suspensions per side
Up to depth of 5500 mm	4 suspensions per side
Above depth of 5500 mm	5 suspensions per side



If $W > 6000$ mm cable brake protection is recommended together with cable tensioner

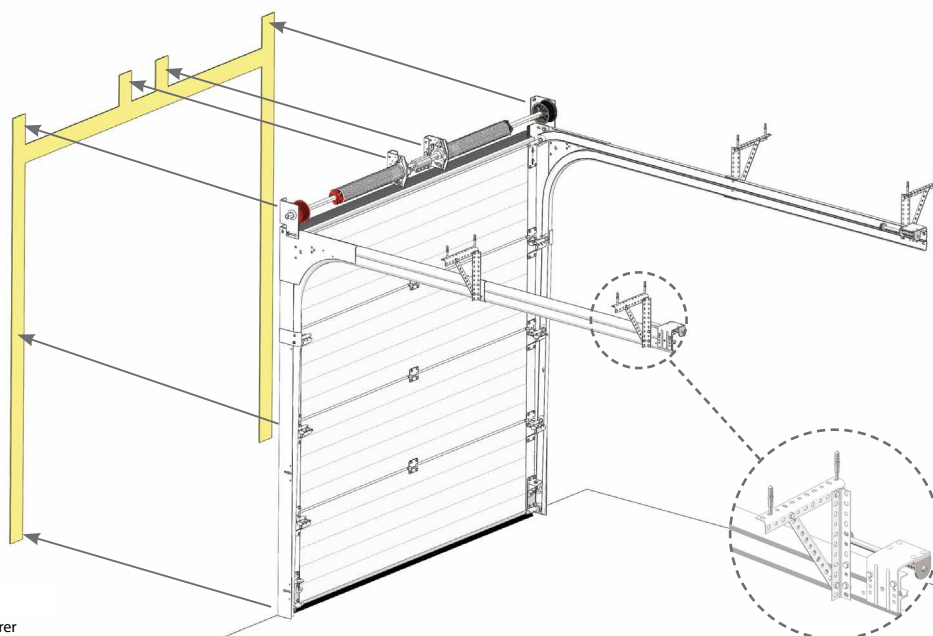
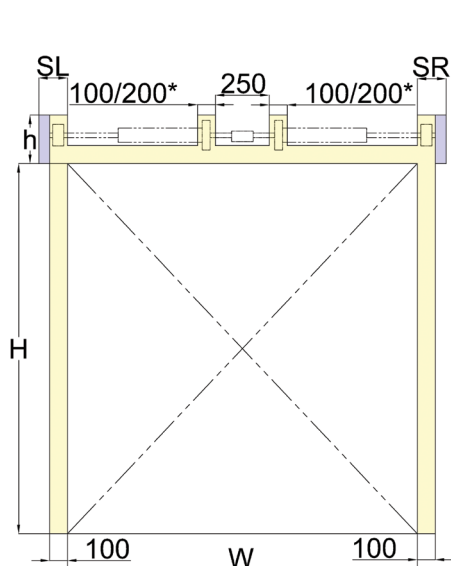
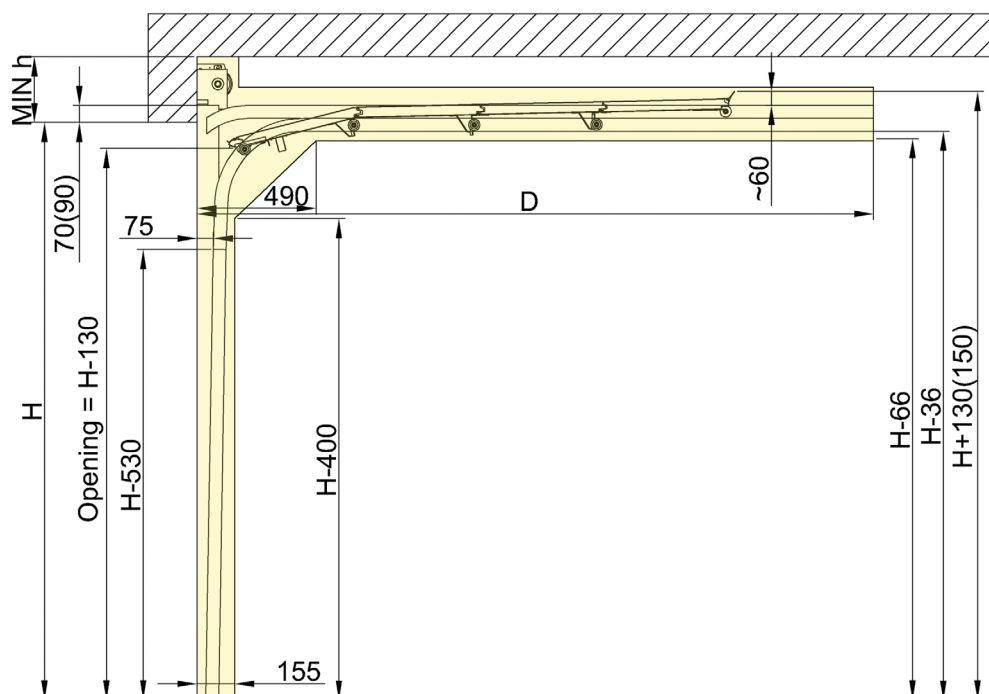

* 200 mm for doors with $\varnothing 152$ mm springs

For $W > 5000$ mm regarding the quantity of springs consult the manufacturer

LHR-RM

Required sideroom	SL	SR
Manual operation	110	110
Electric motor on shaft	110	220-320
Chain host	110	220-320
With retractable motor	110	110

Number or required suspensions	
Up to depth of 3500 mm	2 suspensions per side
Up to depth of 4500 mm	3 suspensions per side
Up to depth of 5500 mm	4 suspensions per side
Above depth of 5500 mm	5 suspensions per side

Required headroom	h	D	Opening
Manual operation	120	H + 700	H - 170
With retractable motor	150	H + 700*	H - 100
Electric motor on shaft	120	H + 700	H - 170



Max weight 450 kg

Max w = 6000 mm

* H + 1100 with sommer operator

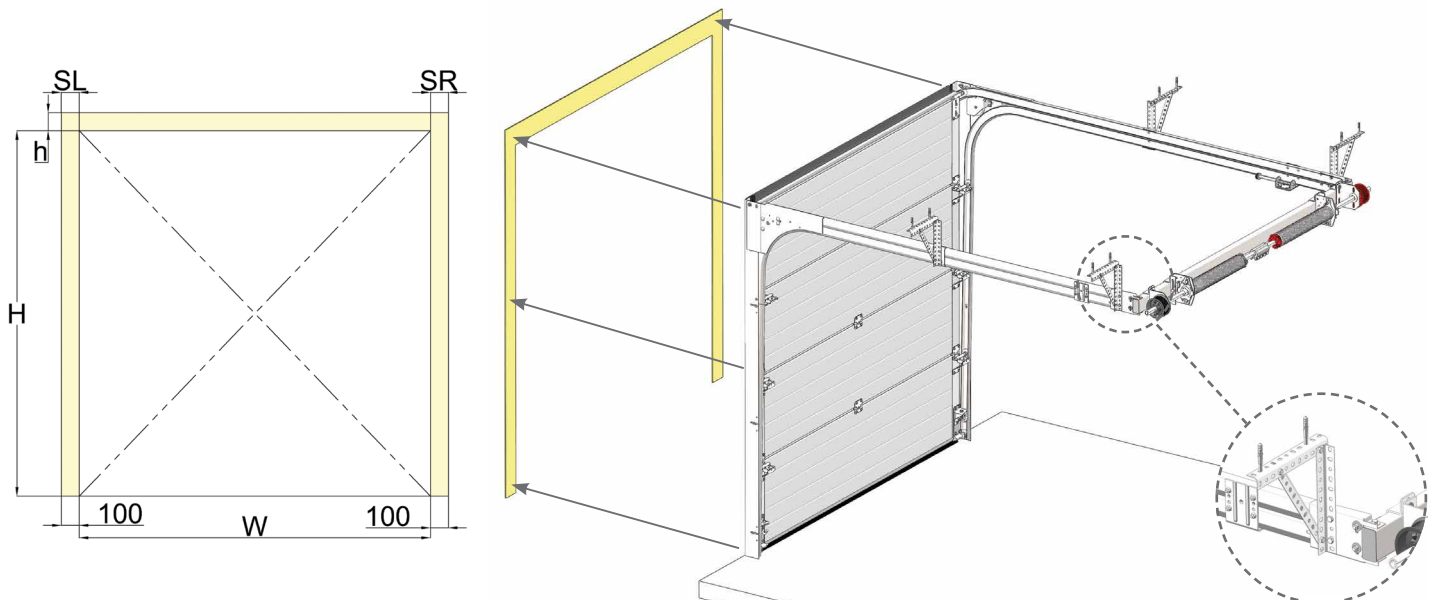
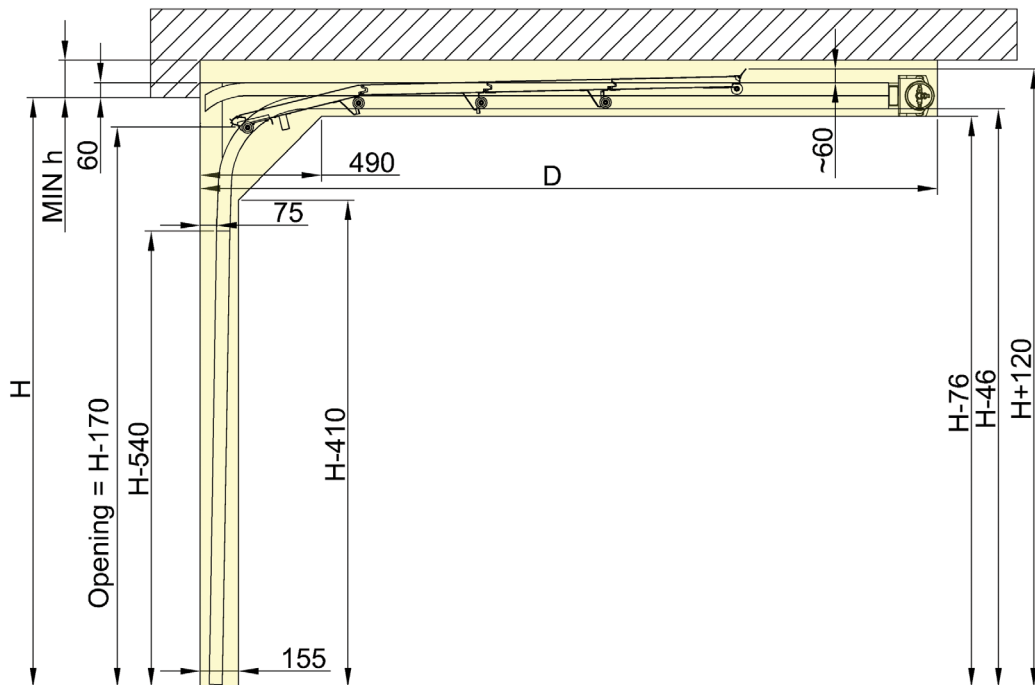

STD-RM

Required sideroom	SL	SR
Manual operation	130	130
Electric motor on shaft	130	240-340
Chain host	130	240-340

Number or required suspensions	
Up to depth of 3500 mm	2 suspensions per side
Up to depth of 4500 mm	3 suspensions per side
Up to depth of 5500 mm	4 suspensions per side

Required headroom	h	D	Opening
Manual operation	190	H + 1220	H*
Electric motor on shaft	190	H + 1220	H*
With wicket door	200	H + 1220	H*
With retractable motor	235	H + 1220	H*



W max = 6000 mm

Max weight 450 kg

* For doors wider than 4500 mm or with wicket door daylight opening will be H - 40 mm

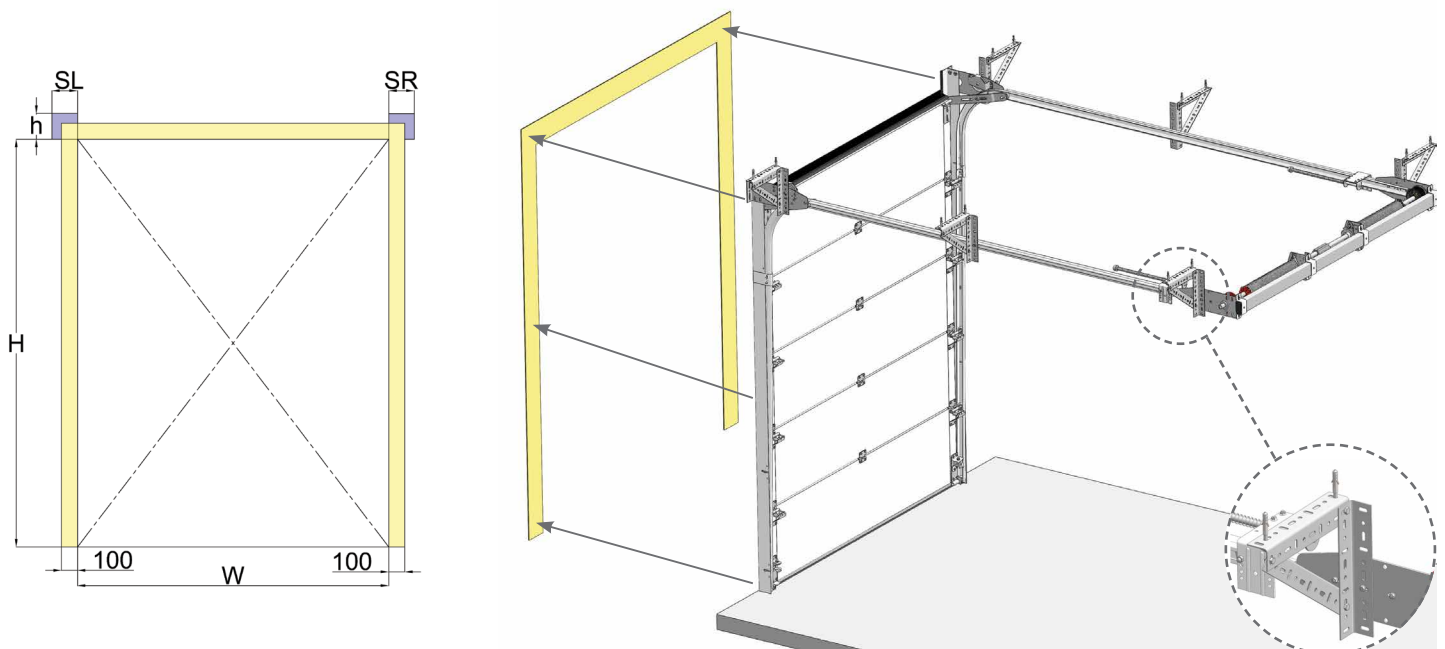
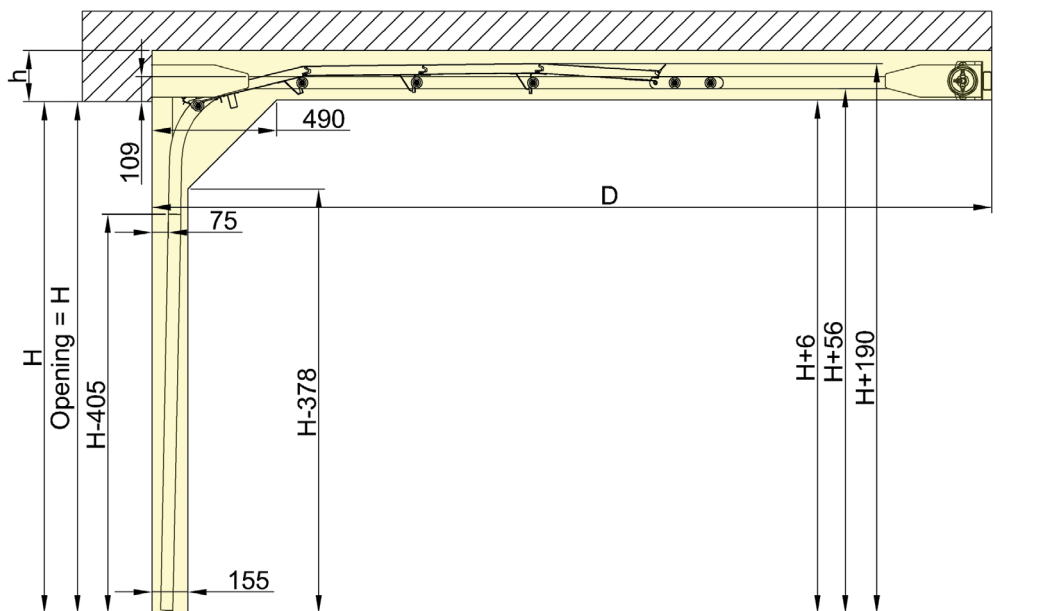

HL-TM

Required sideroom	SL	SR
Manual operation	130	130
Electric motor on shaft	130	240-340
Chain host	130	240-340

Number or required suspensions	
Up to depth of 3500 mm	2 suspensions per side
Up to depth of 4500 mm	3 suspensions per side
Up to depth of 5500 mm	4 suspensions per side
Above depth of 5500 mm	5 suspensions per side

Required headroom	$h = \text{min } 700, \text{ max } 4500$
Opening	H
Installation depth	$D = H - HL + 1010$

Max HL = 4200 mm

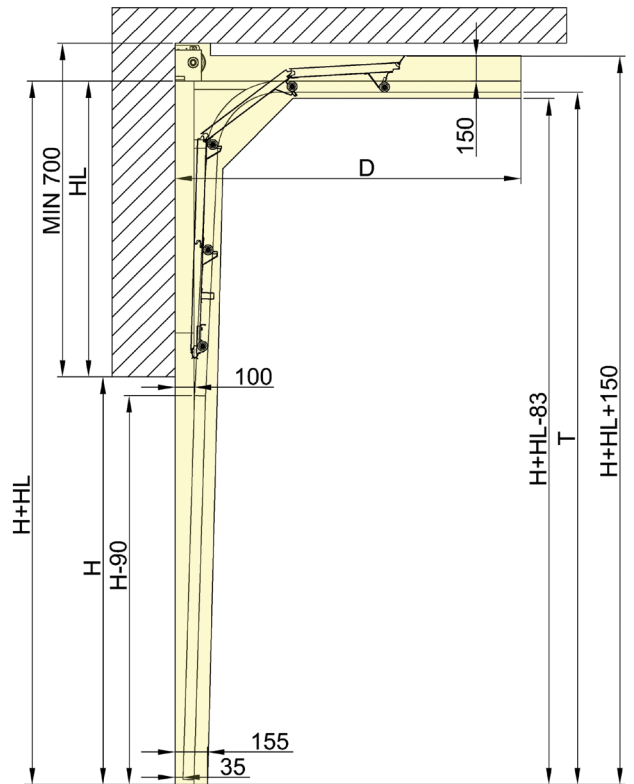

Height & HL correlation		
$H \leq 4500$	$HL \leq 1370$	AB = 200
$4500 < H \leq 6000$	$HL \leq 4200$	AB = 300
H > 6000 on request		

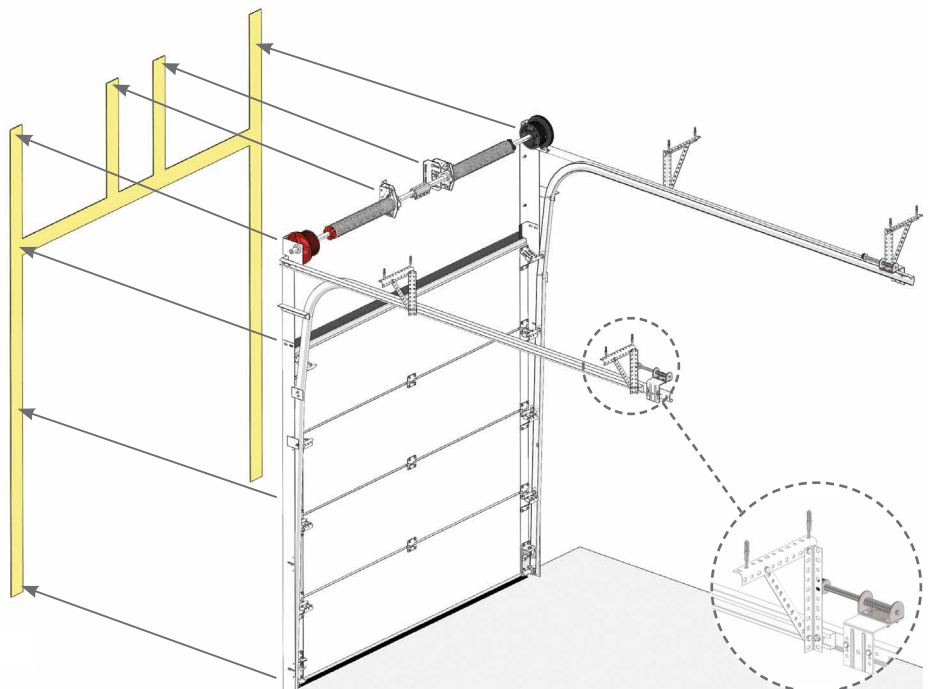
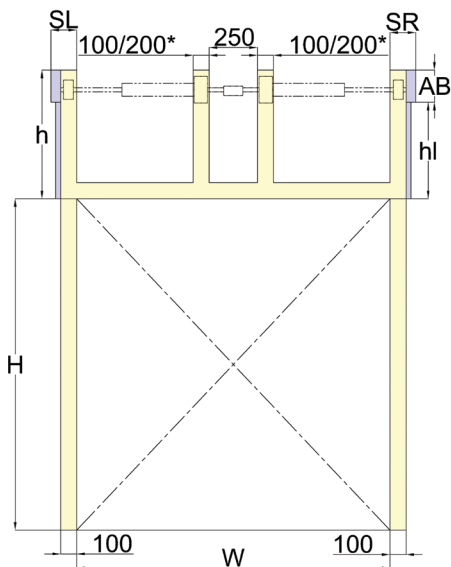

* 200 mm for doors with $\varnothing 152$ mm springs

For $W > 5000$ mm regarding the quantity of springs consult the manufacturer

VL-TM

Required sideroom	SL	SR
Manual operation	130	130
Electric motor on shaft	130	240-340
Chain host	130	240-340

Required headroom	$h = H + 320$
Opening	H
Installation depth	D = 400, $H \leq 3300$ D = 450, $3300 < H \leq 6000$, max weight 500 kg D = 550, $3300 < H \leq 6000$, max weight 750 kg H > 6000 on request

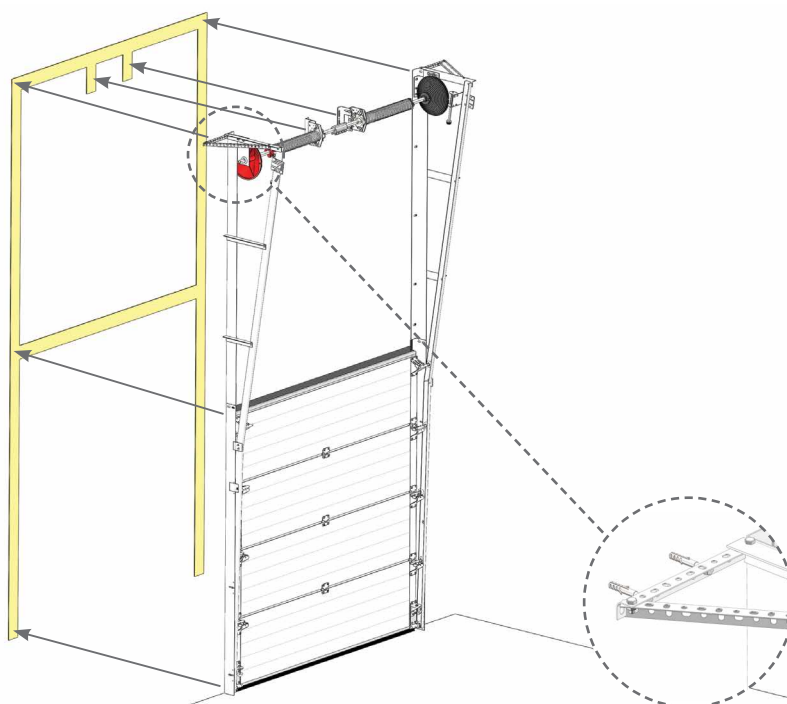
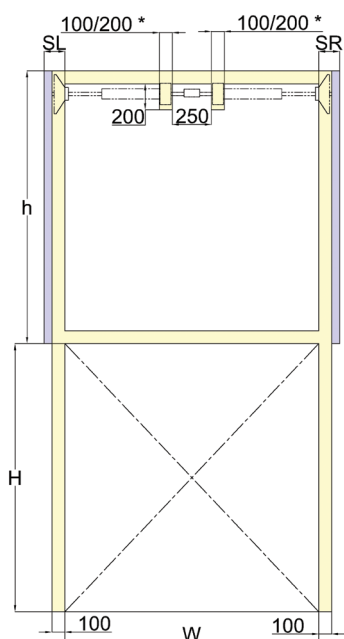
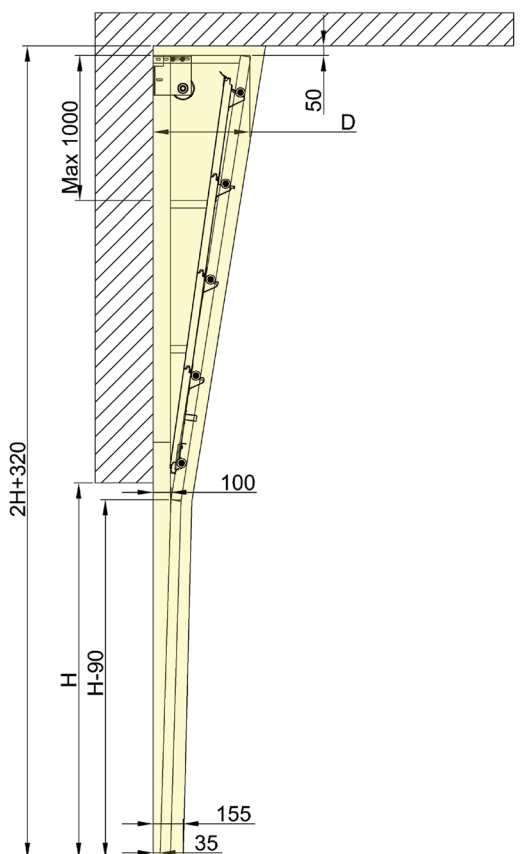

* 200 mm for doors with $\varnothing 152$ mm springs

For $W > 5000$ mm regarding the quantity of springs consult the manufacturer

HL-MM1 with lower torsion spring shaft

Required sideroom	SL	SR
Manual operation	240	240
Electric motor on shaft	240	350-450
Chain host	240	350-450

Number or required suspensions	
Up to depth of 3500 mm	2 suspensions per side
Up to depth of 4500 mm	3 suspensions per side
Up to depth of 5500 mm	4 suspensions per side
Above depth of 5500 mm	5 suspensions per side

Required headroom	$h = \text{min } 1000, \text{max } 4360$
Opening	H
Installation depth	$D = H - hl + 1010$

	C	MF
$W \leq 3500$, max weight 200 kg	50	$H + (241 \div 282)$



It's not able to use cable failure safety device.

For wicket door with anti-panic lock consult the manufacturer.

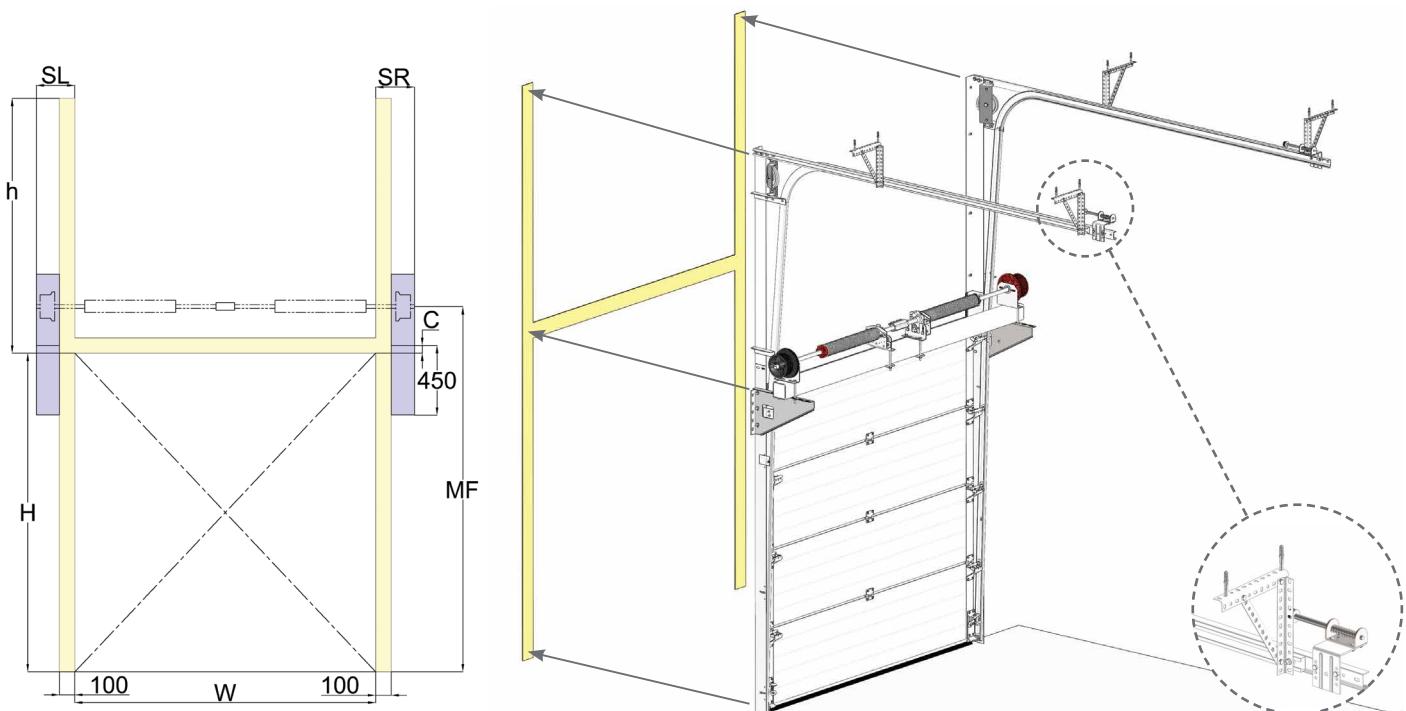
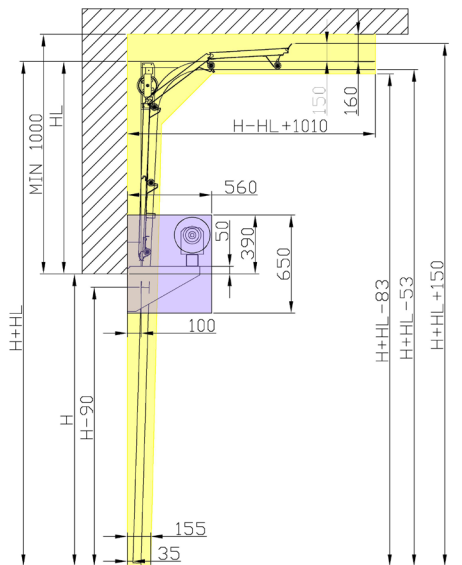

HL-MM2 with lower torsion spring shaft

Required sideroom	SL	SR
Manual operation	290	290
Electric motor on shaft	290	400-500
Chain host	290	400-500

Number or required suspensions	
Up to depth of 3500 mm	2 suspensions per side
Up to depth of 4500 mm	3 suspensions per side
Up to depth of 5500 mm	4 suspensions per side
Above depth of 5500 mm	5 suspensions per side

Required headroom	$h = \min 2020, \max 4360$
Opening	H
Installation depth	$D = H - hl + 1010$

	C	MF
$3500 < W \leq 6000$	400	$H + (586 \div 652)$



Max weight 600 kg.

For wicket door with anti-panic lock consult the manufacturer.

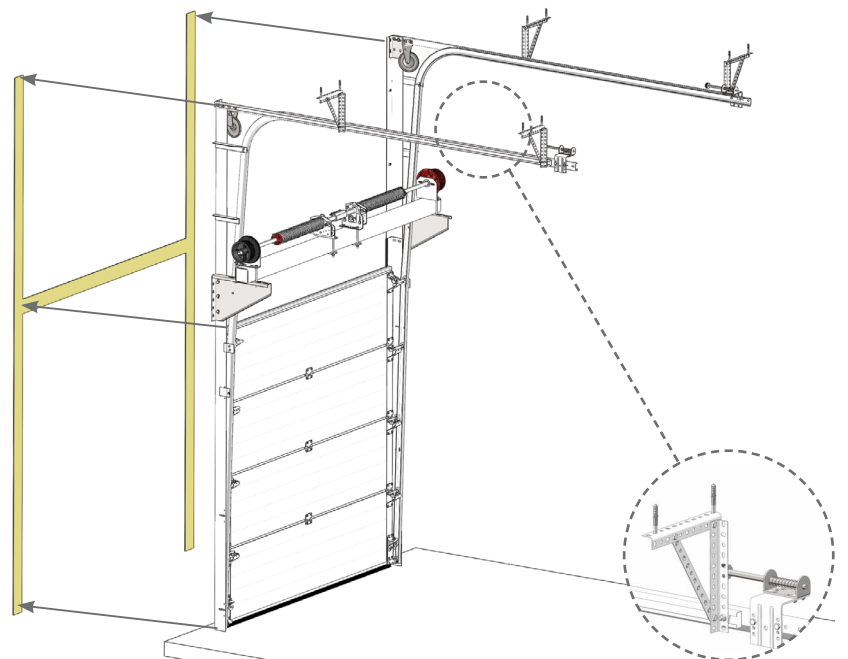
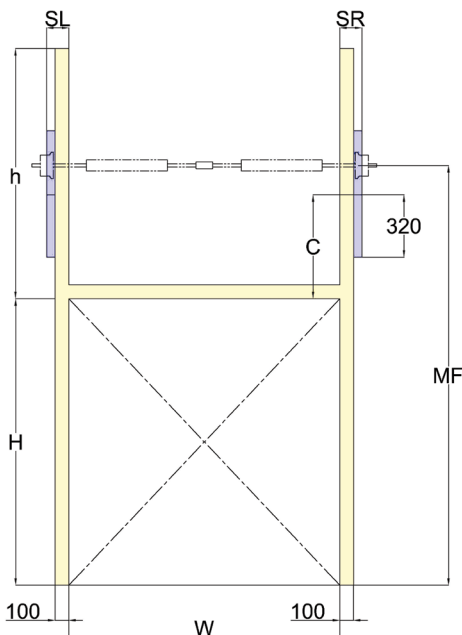
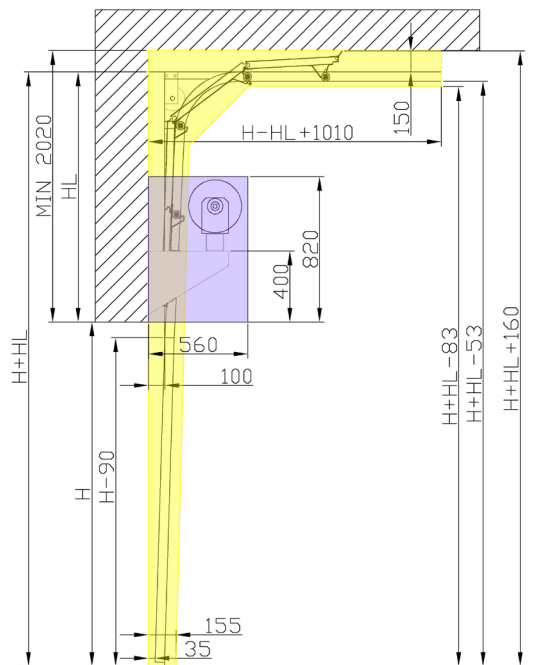

VL-MM1 with lower torsion spring shaft

Required sideroom	SL	SR
Manual operation	240	240
Electric motor on shaft	240	350-450
Chain host	240	350-450

	C	MF
$W \leq 3500$, max weight 200 kg	50	$H + (241 \div 282)$

Required headroom	$h = H + 320$, min 1000
Opening	H
Installation depth	D = 300



It's not able to use cable failure safety device.

For wicket door with anti-panic lock consult the manufacturer.

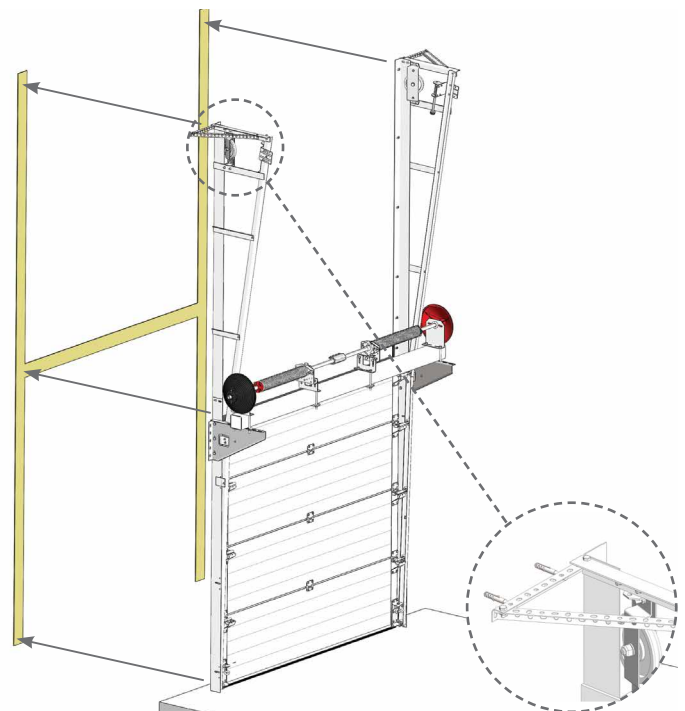
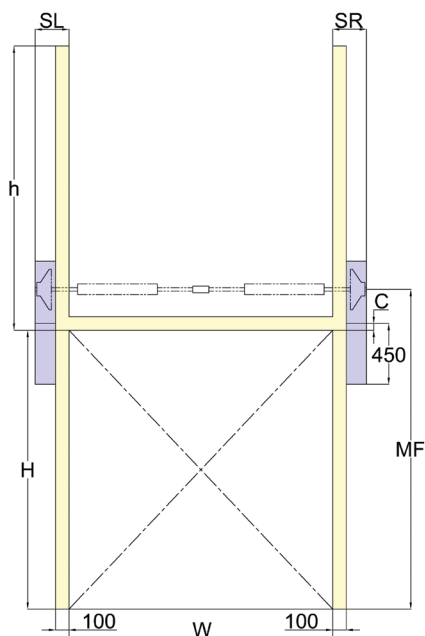
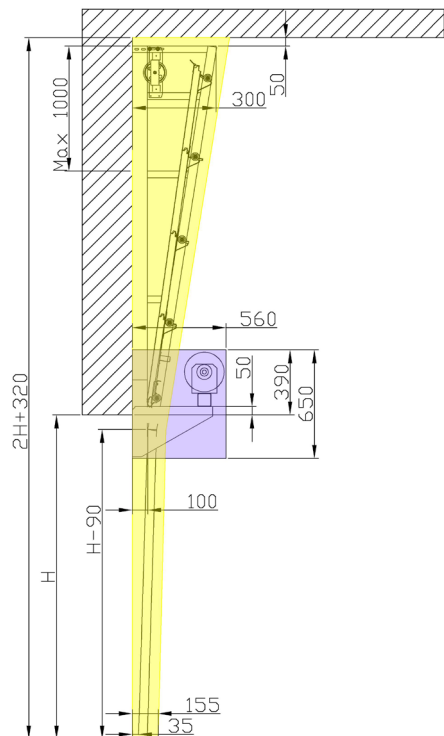

VL-MM2 with lower torsion spring shaft

Required sideroom	SL	SR
Manual operation	310	310
Electric motor on shaft	310	400-545
Chain host	310	400-545

	C	MF
$3500 < W \leq 6000$	400	$H + (586 \div 652)$

Required headroom	$h = H + 320$, min 2200
Opening	H
Installation depth	D = 300



Max weight 600 kg.

For wicket door with anti-panic lock consult the manufacturer.

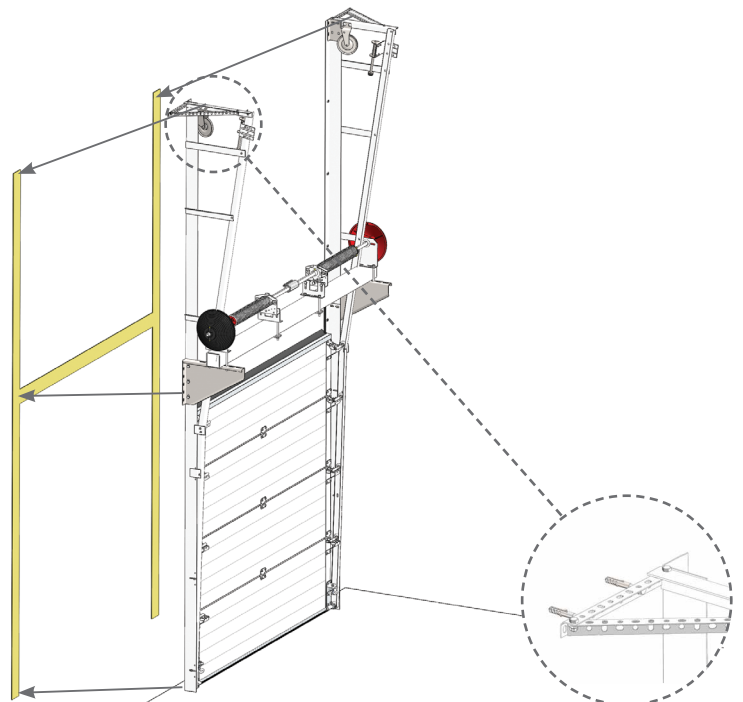
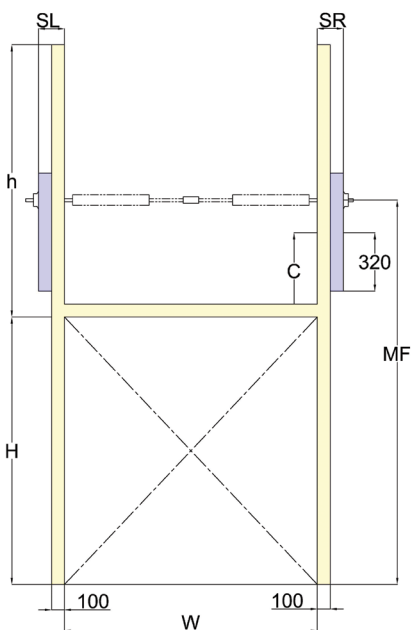
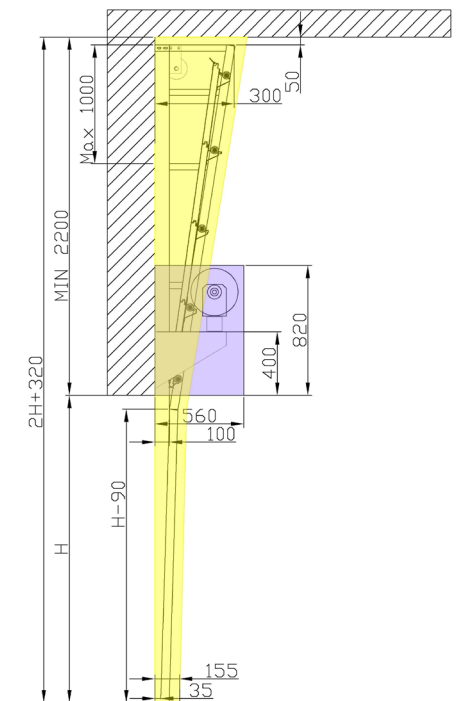

STD-PR

Required sideroom	SL	SR
Manual operation	110	110
Electric motor on shaft	110	220-320
Chain host	110	220-320

Number or required suspensions	
Up to depth of 3500 mm	2 suspensions per side
Up to depth of 4500 mm	3 suspensions per side
Up to depth of 5500 mm	4 suspensions per side
Above depth of 5500 mm	5 suspensions per side

Required headroom	$\alpha \leq 25^\circ$	$25^\circ < \alpha \leq 35^\circ$	$35^\circ < \alpha \leq 45^\circ$	D
$H \leq 2500$	370	370	on request	H + 510
$2500 < H \leq 5000$	430	430	on request	H + 510
$5000 < H \leq 6000$	505	505	on request	H + 510
$H > 6000$	on request			

Max $\alpha = 45^\circ$

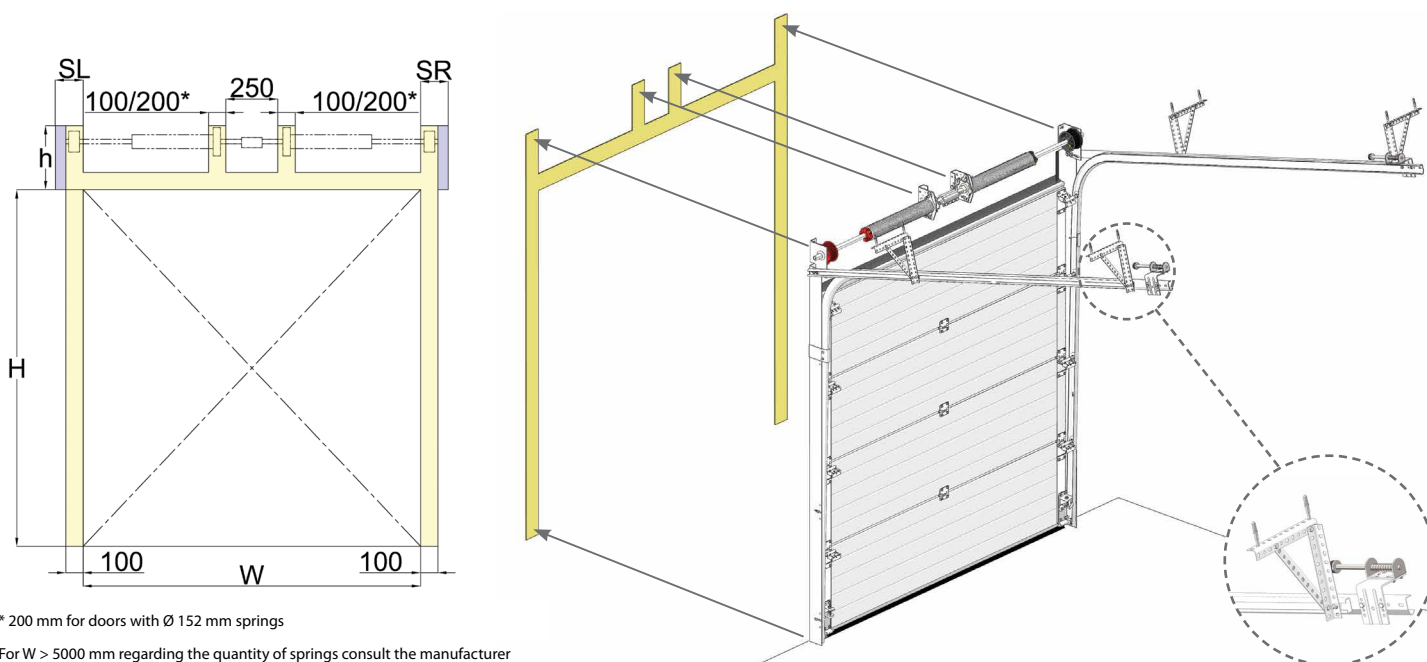
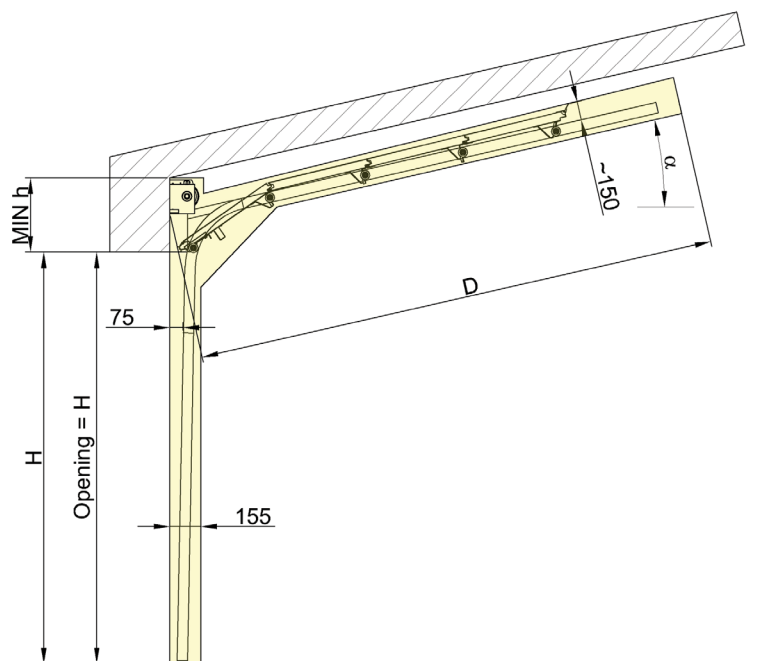

* 200 mm for doors with $\varnothing 152$ mm springs

For $W > 5000$ mm regarding the quantity of springs consult the manufacturer

RM-PR

Required sideroom	SL	SR
Manual operation	110	110
Electric motor on shaft	110	220-320
Chain host	110	220-320
With retractable motor	110	110

Number or required suspensions	
Up to depth of 3500 mm	2 suspensions per side
Up to depth of 4500 mm	3 suspensions per side
Up to depth of 5500 mm	4 suspensions per side
Above depth of 5500 mm	5 suspensions per side

Required headroom	h	D	Opening
Manual operation	120	H + 700	H - 170
Electric motor on shaft	120	H + 700	H - 170
With retractable motor	150	H + 700*	H - 100



W max = 6000 mm
 * H + 1100 with sommer operator

Max $\alpha = 15^\circ$
 $\alpha > 15^\circ$ on request

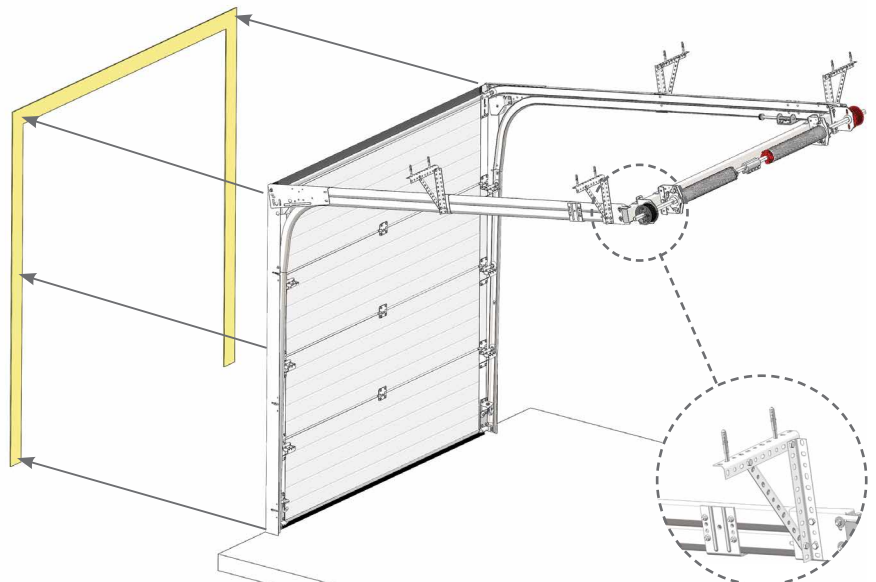
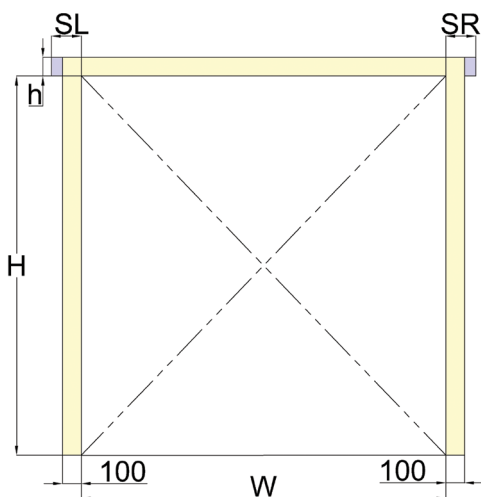
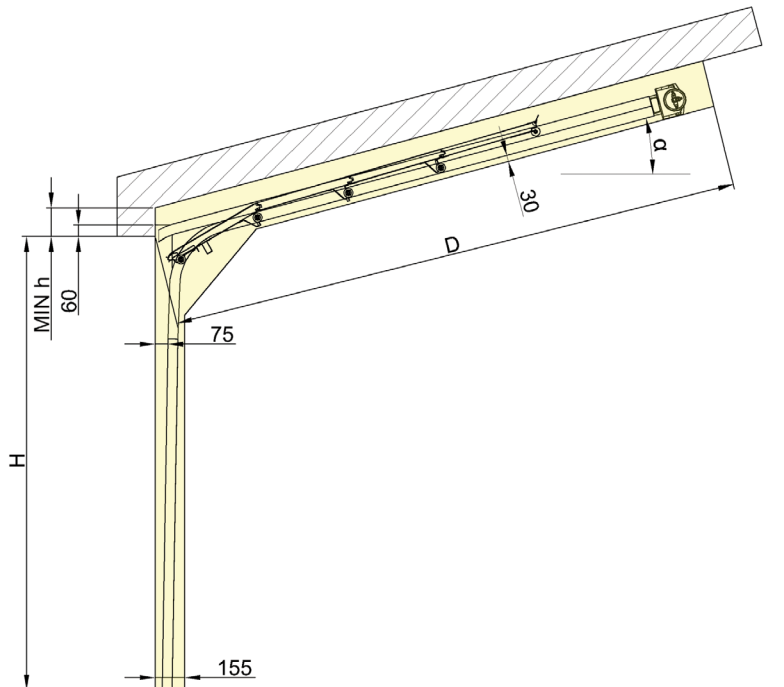

FM-PR

Required sideroom	SL	SR
Manual operation	110	110
Electric motor on shaft	110	220-320
Chain host	110	220-320

Number or required suspentions	
Up to depth of 3500 mm	2 suspentions per side
Up to depth of 4500 mm	3 suspentions per side
Up to depth of 5500 mm	4 suspentions per side
Above depth of 5500 mm	5 suspentions per side

Required headroom	$\alpha \leq 25^\circ$	$25^\circ < \alpha \leq 35^\circ$	$35^\circ < \alpha \leq 45^\circ$	D	Opening
$H \leq 2500$	270	310	350	$H + 550$	$H - 130$
$2500 < H \leq 5030$	310	310	on request	$H + 550$	$H - 130$
$H > 5030$	on request				

Max $\alpha = 45^\circ$



If $W > 6000$ mm cable brake protection is recommended together with cable tensioner

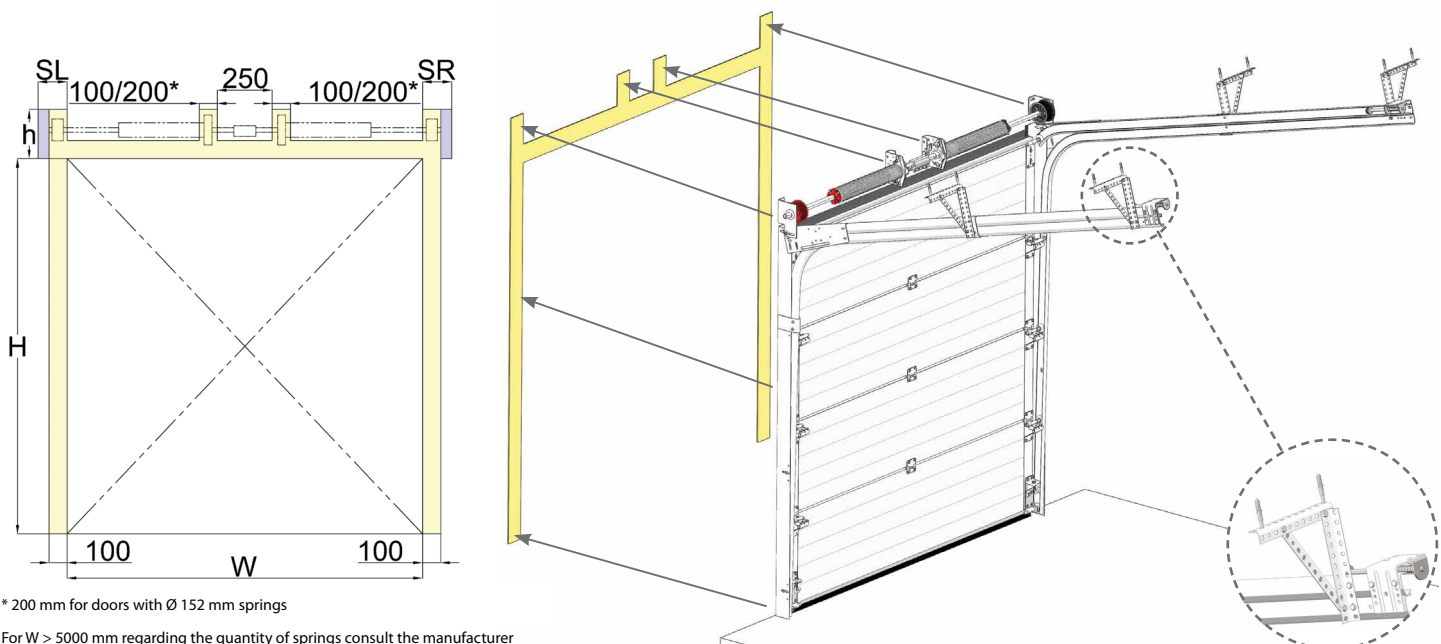
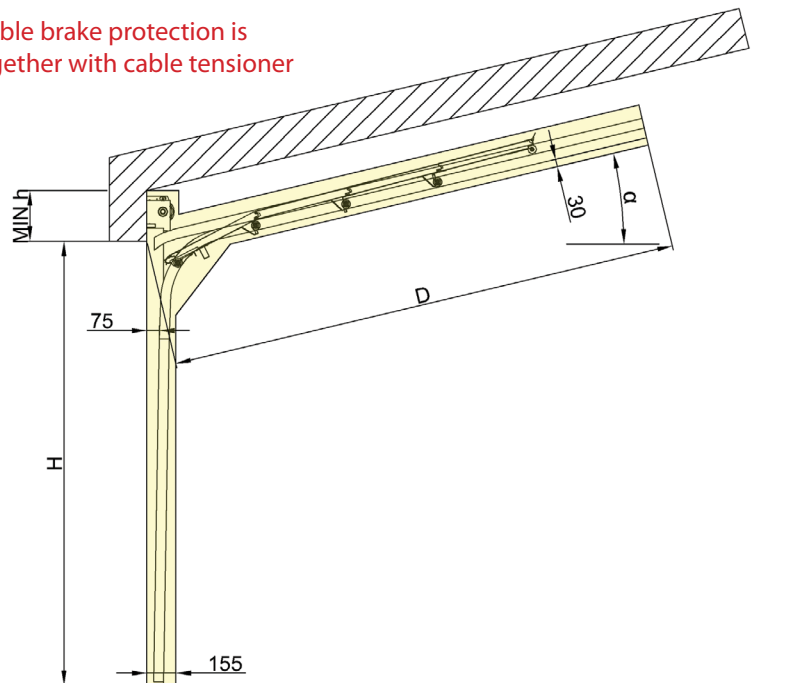

* 200 mm for doors with $\varnothing 152$ mm springs

For $W > 5000$ mm regarding the quantity of springs consult the manufacturer

TLP 80 THERMO panels / tracks

Panel type	S (mm)	Thermal conductivity (λ^D {W/mK})	Panel weight		U value W m ² K
			Kg/m	Kg/m ²	
R-600	80	0,023	7,4	12,3	0,28

Section type	U value (W/m ² K)	Wind load resistance class	Water penetration class	Air permeability class	Acoustic insulation (dB)
Sandwich	0,48 - 1	5	3	2	-24
FVThermo	1,6 - 2	5	3	3	-

PANEL SURFACES

RIB / stucco



PANEL COLOURS

Painted RAL



STANDARD COLOURS

RAL 9016 (both sides)

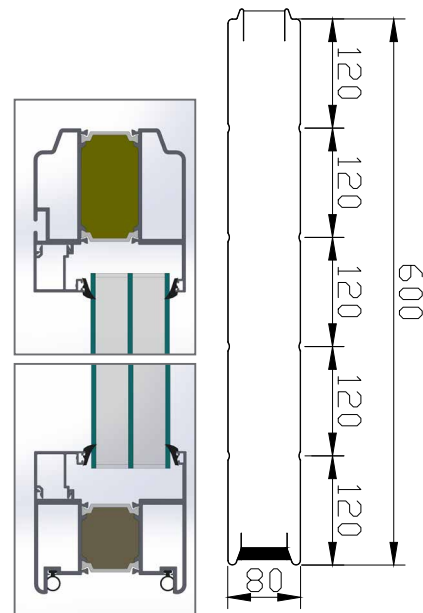

STD / LHR-FM / HL-TM / VL-TM

Required sideroom	STD or LHR-Fm, left / right	HL-TM or VL-TM left / right
Manual operation	140 / 140	160 / 160
Electric motor on shaft	140 / 250-350	160 / 270-370
Chain host	140 / 250-350	160 / 270-370

Lift type	Opening, H	Required headroom, h	Installation depth, D	Daylight opening
STD	H ≤ 5030	460	H + 550	H
	H > 5030 on request			
LHR-FM	H ≤ 5030	310	H + 550	H - 130
HL-TM	H < 6000	720 < h ≤ 4500	H - h + 1310	H
VL-TM	H ≤ 3300	H + 320	450	H
	3300 < H ≤ 6000, max 500 kg	H + 320	500	H
	3300 < H ≤ 6000, max 750 kg	H + 320	600	H
	H > 6000 on request			

LHR-RM / STD-RM

Lift type	Opening, H	Required headroom, h	Installation depth, D	Daylight opening	Required side-room, left / right
LHR-RM	Manual operation	170	H + 740	H - 170	140 / 140
	Electric motor on shaft	170	H + 740	H - 170	140 / 250-350
	With retractable motor	200	H + 740	H - 170	140 / 140
	Chain host	170	H + 740	H - 170	140 / 250-350
STD-RM	Manual operation	240	H + 1260	H*	160 / 160
	Electric motor on shaft	240	H + 1260	H*	160 / 270-370
	With retractable motor	285	H + 1260	H*	160 / 160
	Chain host	240	H + 1260	H*	160 / 270-370



max weight = 450 kg

* For doors wider than 4500 mm daylight opening will be H - 40 mm

Industrial SSD (side sliding sectional door)

Manual					
	WxH (max), mm	h, mm	SL, mm	SR, mm	D, mm
Single leaf	10000x8000	400	750	75	W
Double leaf	20000x8000	400	750	750	W/2

Automatic					
	WxH (max), mm	h, mm	SL, mm	SR, mm	D, mm
Single leaf	10000x8000	1100	1750	300	W-1000
Double leaf	20000x8000	1100	1750	1750	W/2-1000

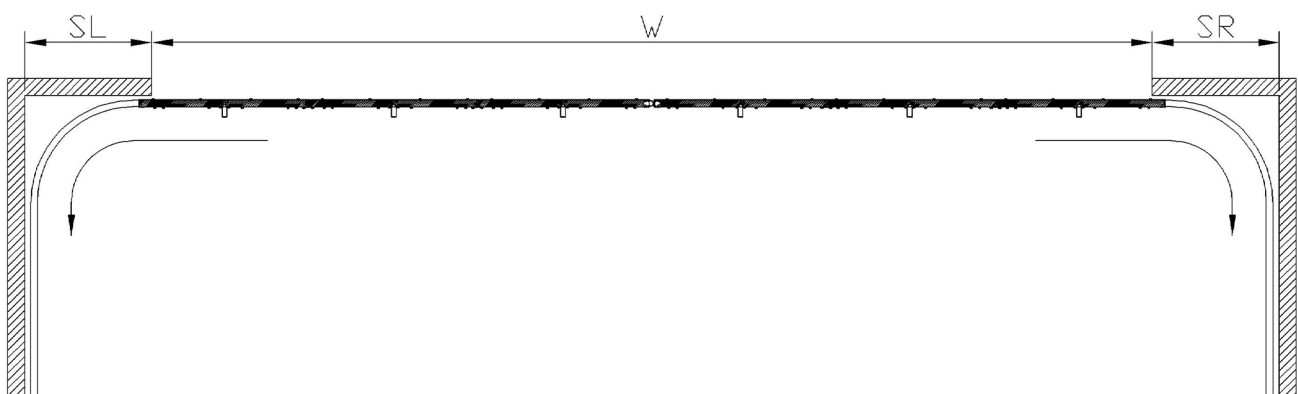
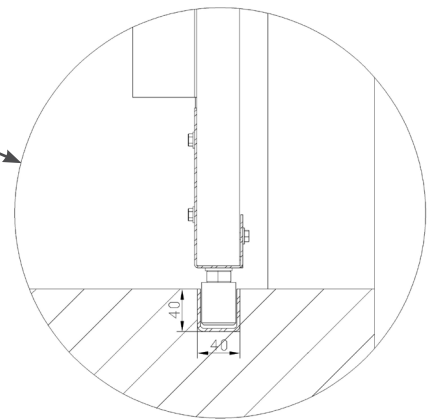
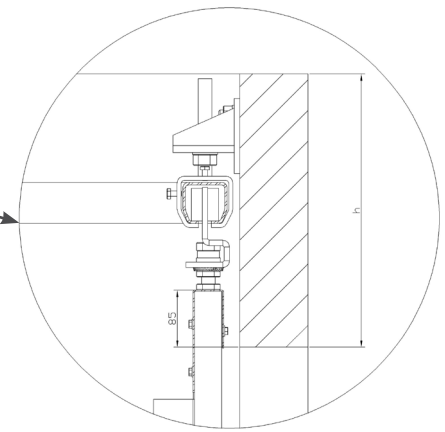
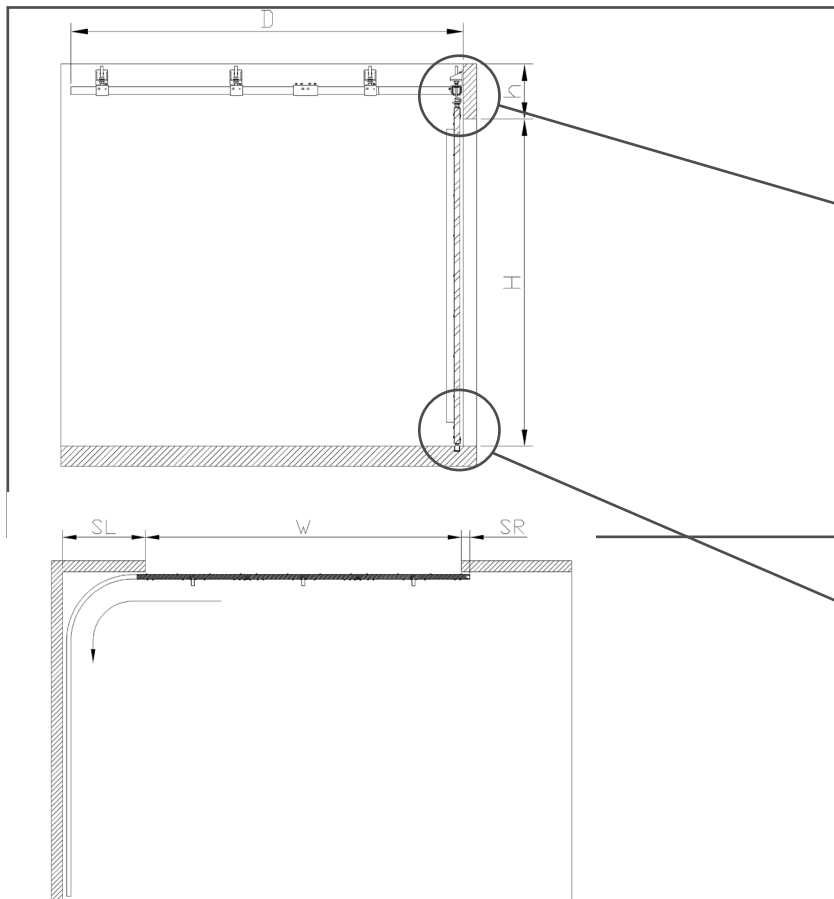
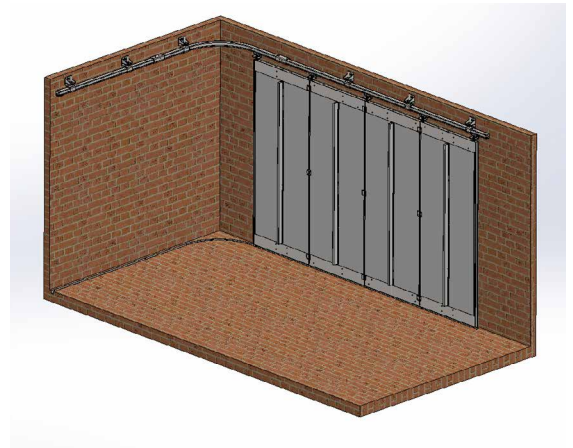

SFD (side framed door)

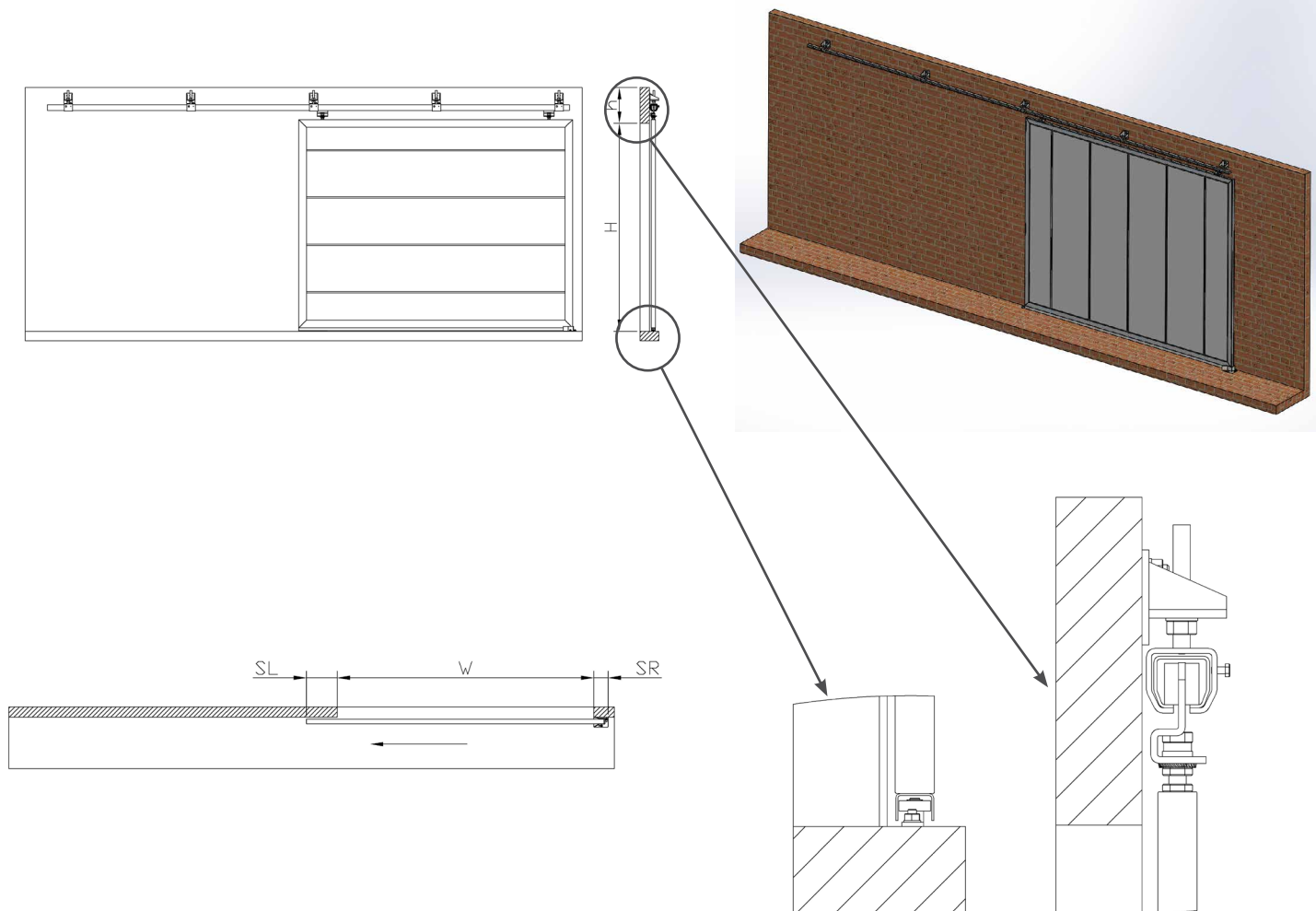

Single leaf				
WxH (max), mm	Max weight, kg	h, mm	SL, mm	SR, mm
3500x2500	170	200	150	140
4000x4000	300	280	300	140
>4000x4000	600	410	300	190
	1200	510	300	190

Double leaf				
WxH (max), mm	Max weight, kg	h, mm	SL, mm	SR, mm
7000x2500	170	200	150	150
8000x4000	300	280	300	140
>8000x4000	600	410	300	190
	1200	510	300	190

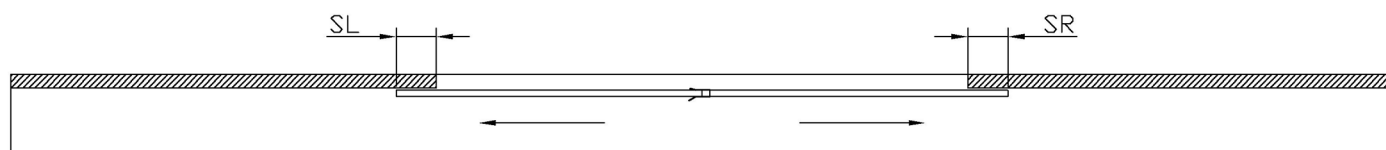

PANELS



PANEL TYPES

Panel type	S (mm)	K		Λ	Panel weight		Tolerances			U value
		Kcal m ² hK	Watt m ² K	Kcal mK	Kg/m	Kg/m ²	Thickness	Width	Length	W m ² K
R-500	40	0,43	0,50	0,017	5,6	11,2	+/- 2	+/- 1	+/- 5	0,52
R-610					6,8	11,2				

Section type	U value (W/m ² K)	Wind class	Water penetration class
Sandwich	1,6	5	3*
Sandwich with windows	1,7	3	3*
Sandwich with pass door	1,8	2	0
FV	4,3	4	3*
FV wicket door	4,3	2	0
FV thermo 40	3,4	4	0

*Exeptional; Agreement between manufacturer and purchaser.

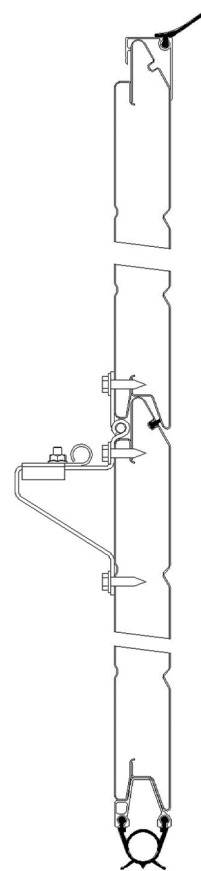
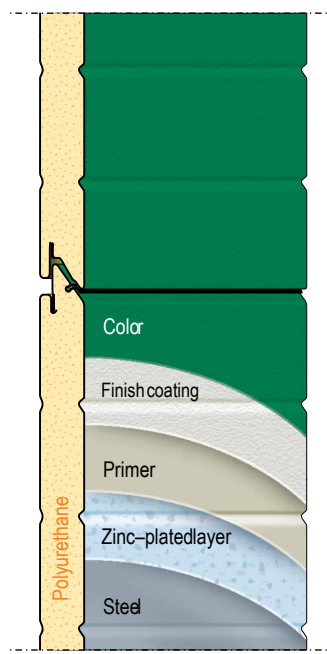

All panels Internal side - ribbed, stucco embossed RAL 9002

PANEL TYPES

RIB

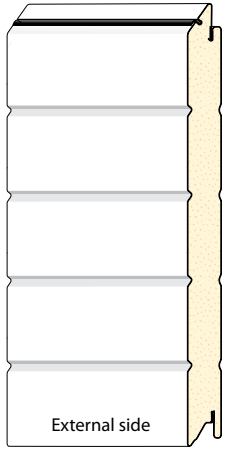

PANEL SURFACES

woodgrain

stucco

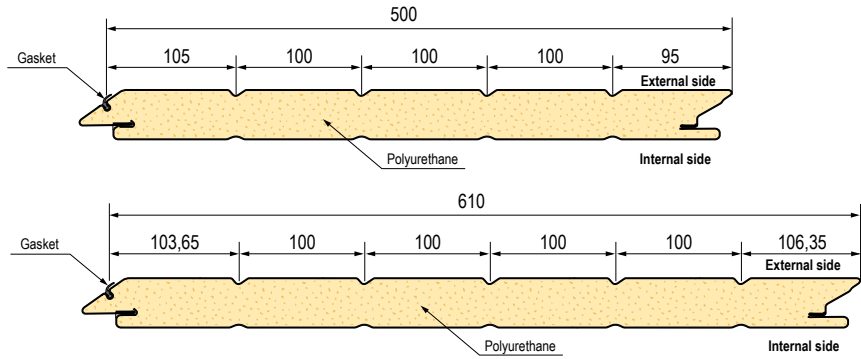
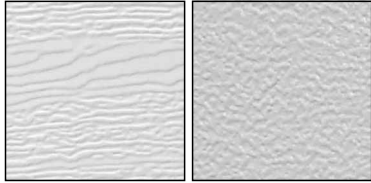

PANEL COLOURS

printed RAL



STANDARD COLOURS

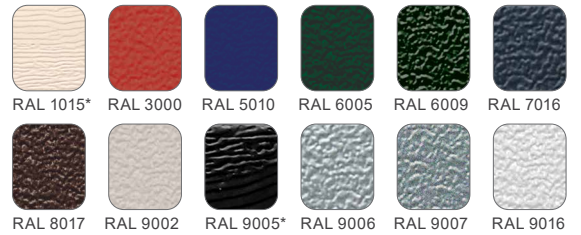

* RAL 1015, RAL 9005 in woodgrain only.

MACRORIB

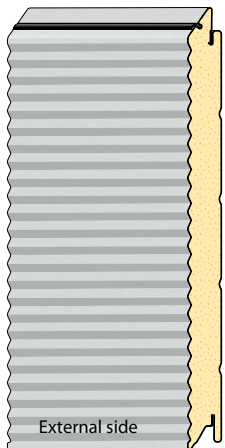

PANEL SURFACES

stucco



Standard colour: RAL9007.

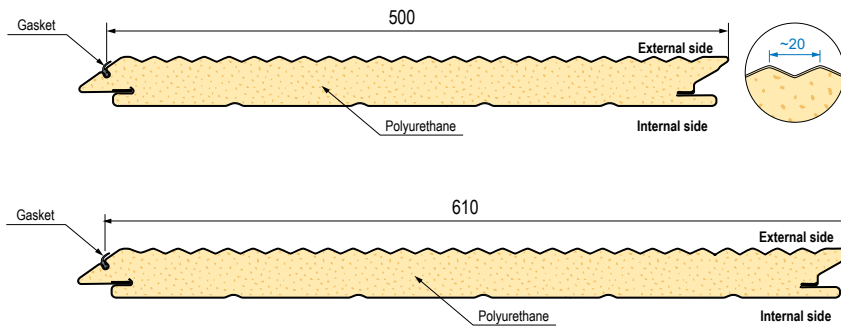

PANEL COLOURS

printed RAL



STANDARD COLOURS



ALU-framed PANEL TYPES

Full View

Double insulated acrylic glazing
Anti-scratch acrylic glazing (outside/inside)

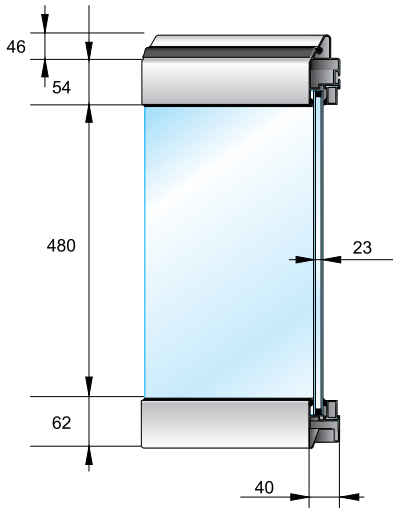

Natural Safety glass

Natural safety glass clear single*
Natural safety glass clear double*

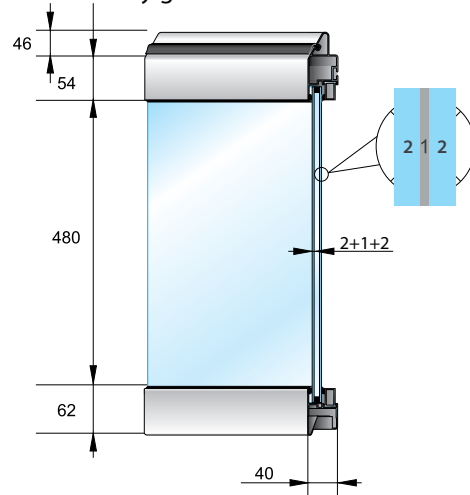

Sandwich filling / stucco

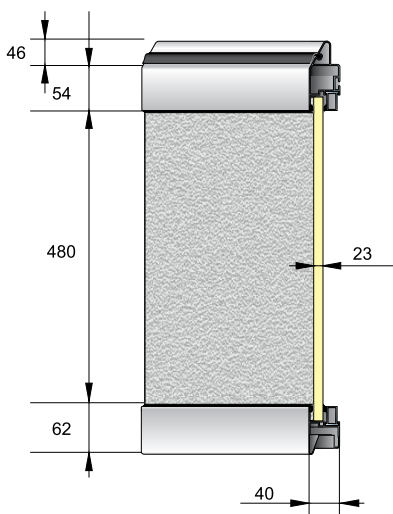

Sandwich filling / smooth

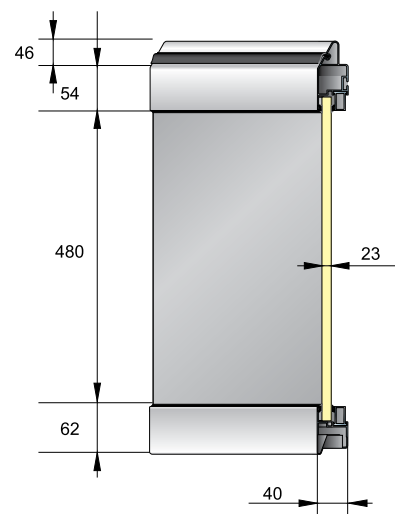

TLT

Perforated, galvanized and coated steel sheet filling

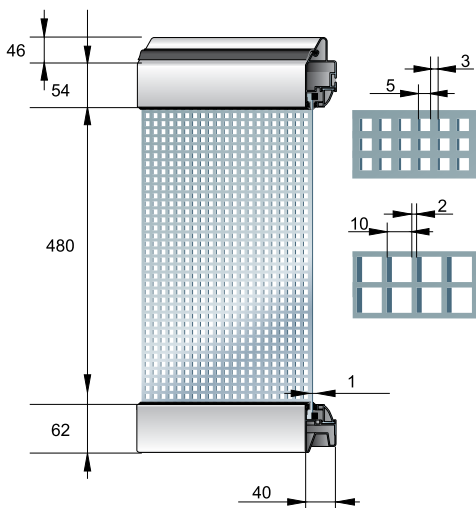

ALU-framed PANEL TYPES

40 mm section

Full vision sections with FV-thermo profile can be glazed in same way as FV-aluminium profile.

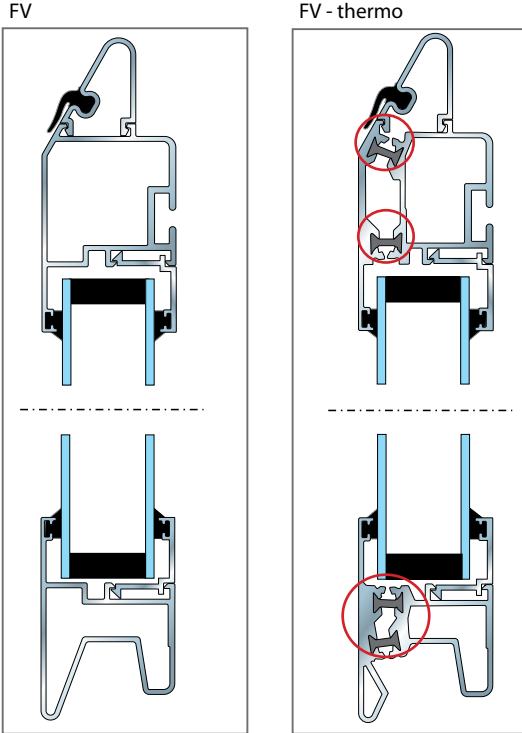

80 mm section

80 mm FV thermo.

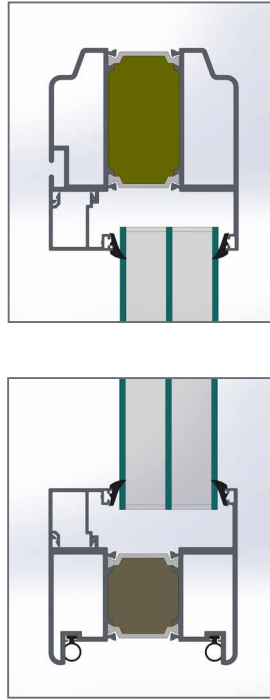

Glazing



Standard clear acrylic glazing



Scratch-proof clear acrylic glazing

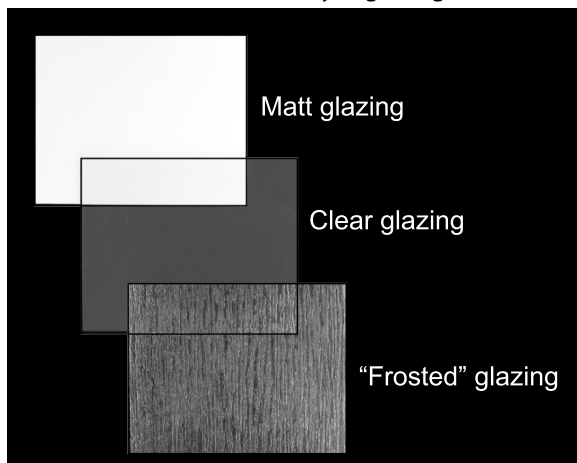

Matt glazing

Clear glazing

"Frosted" glazing

ALU-framed PANEL TYPES

Double insulated Acrylic (Clear / Matt / "Frosted") glazing

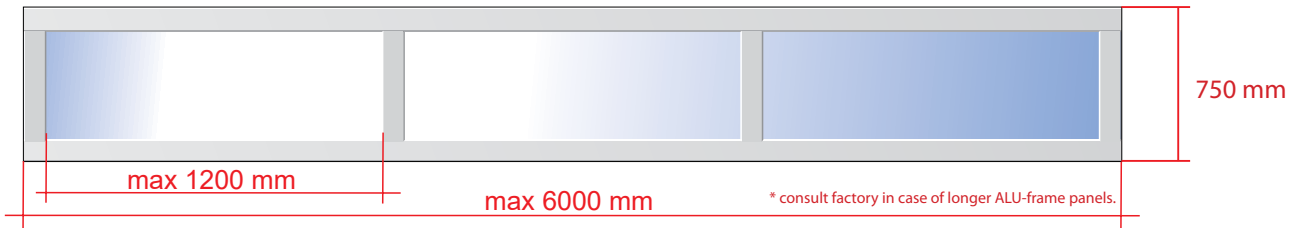

Thermo profiles

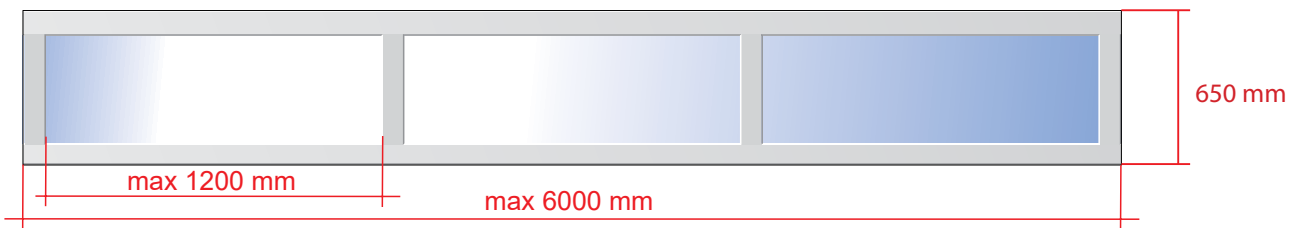

Real Safety Glass glazing

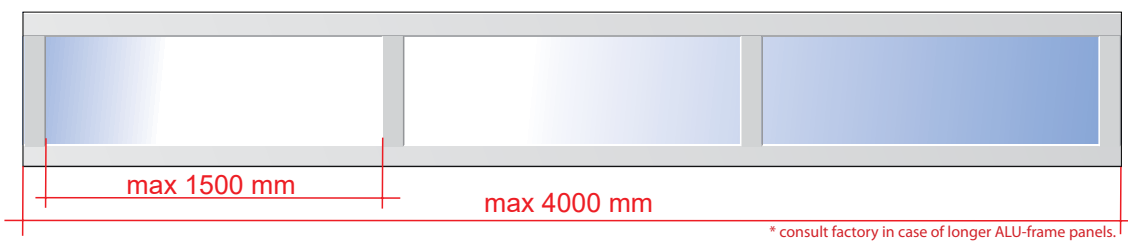

Continous glazing

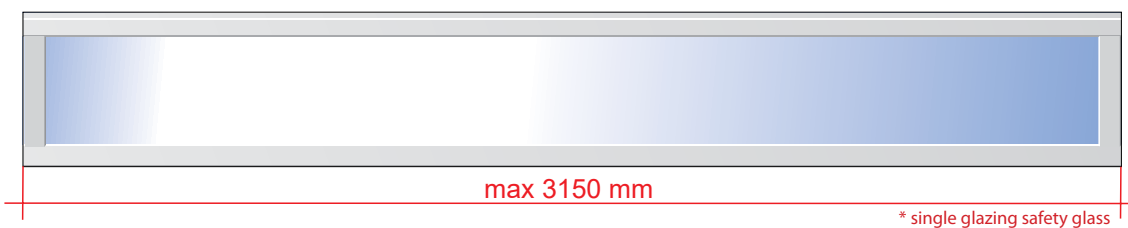
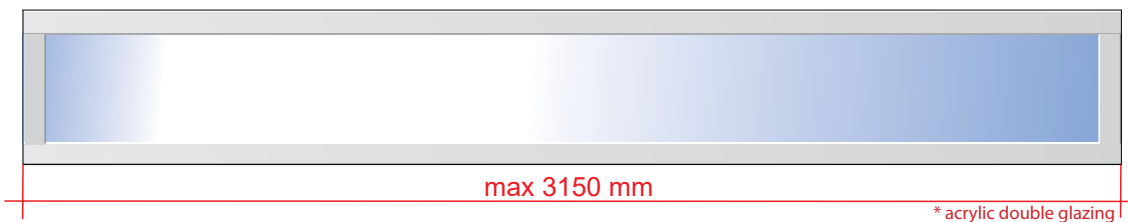

Reinforcement profiles ≤ 8000

Opening width, W	Profile type	Option No.	Main location on panel	Quantity of reinforcements
$W \leq 4500$	-	-	-	-
$4500 < W \leq 5000$	Bottom reinforced + omega	1-A	Top of panel (for omega) Top partition of panel	1 + 1 = 2
	Omega	1-B		2
$5000 < W \leq 5500$	Omega	2	Top partinion of panel	on every second doorpanel
$5500 < W \leq 6000$	Omega	3	Top partition of panel	on every second doorpanel + 1 on top
$6000 < W \leq 8000$	Omega	4	Top partition of panel	on each doorpanel + 1 on top

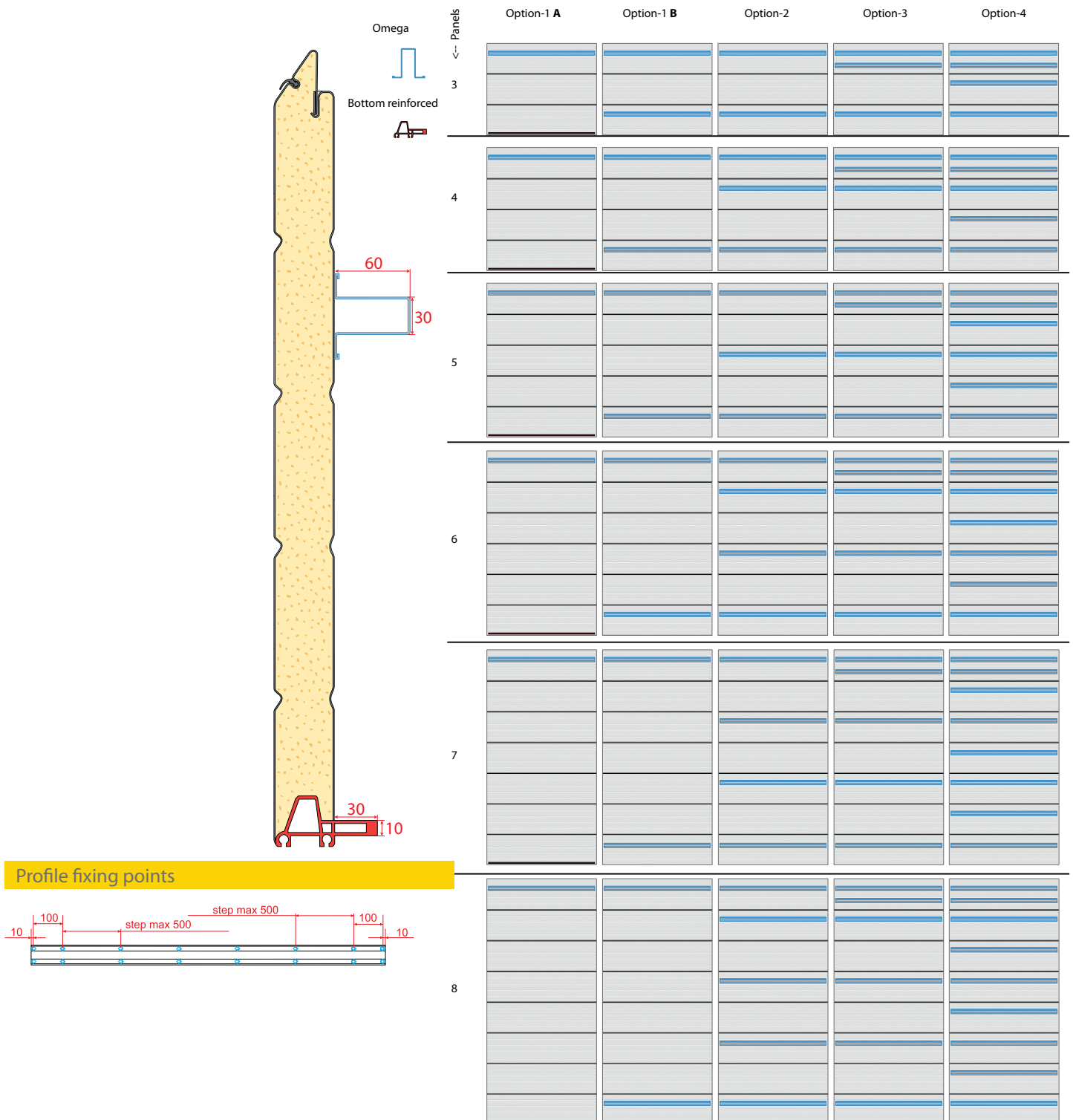

Reinforcement profiles > 8000

Opening width, W	Profile type	Option No.	Main location on panel	Quantity of reinforcements
8000 < W ≤ 9000	Triangular	5	Middle partition	on every second doorpanel
9000 < W	Triangular	6	Middle partition	on each doorpanel

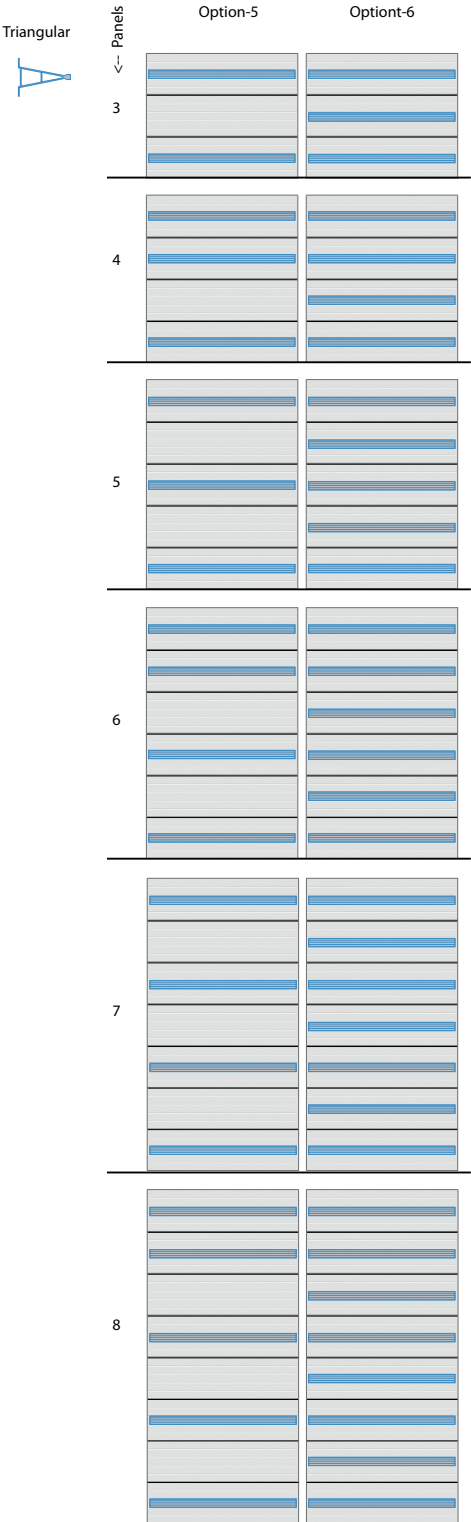
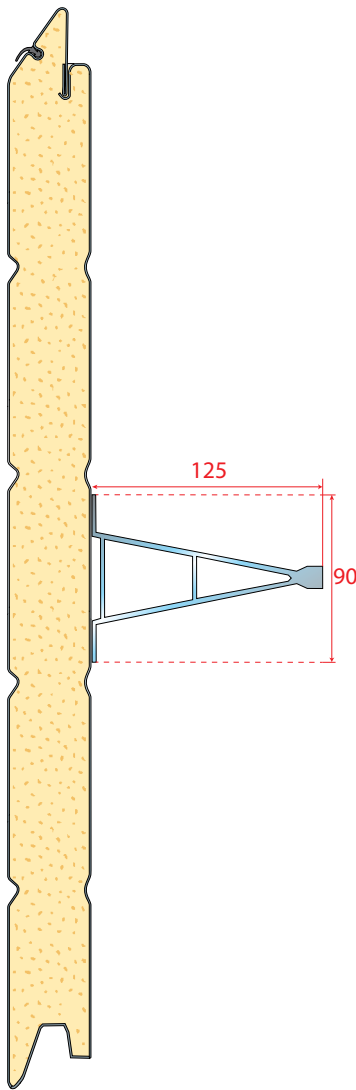

Profile fixing points

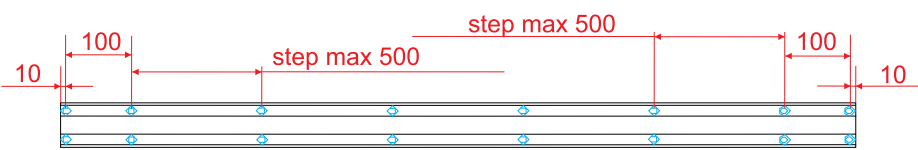

Reinforcement profiles on glazed panels

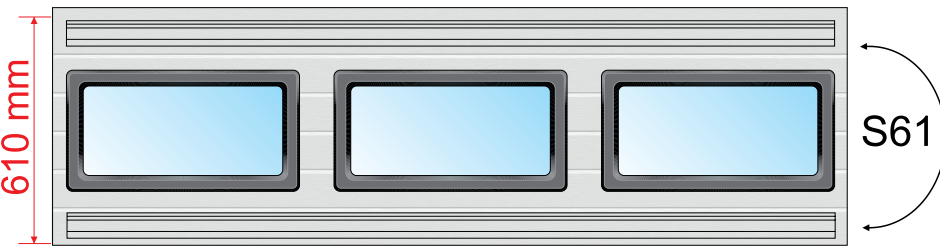
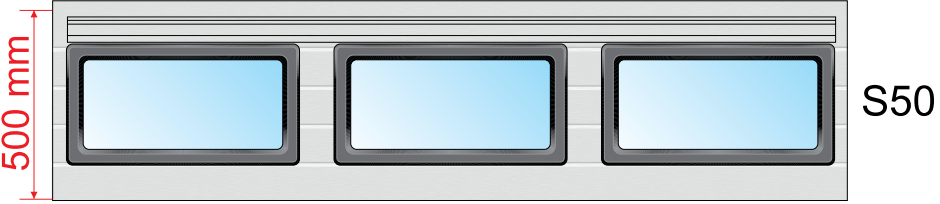

Profile fixing points

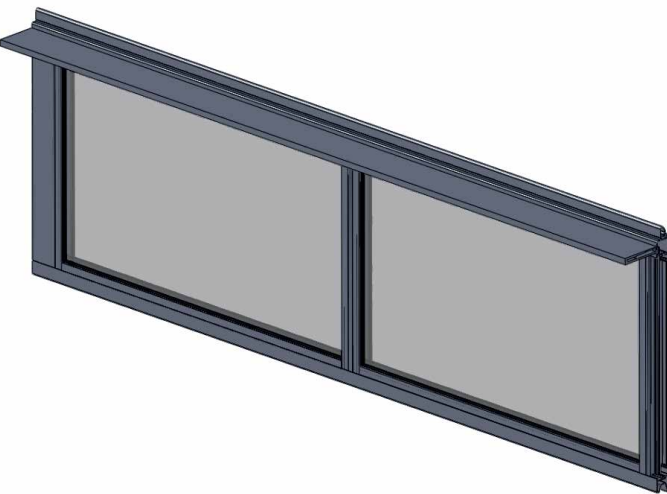
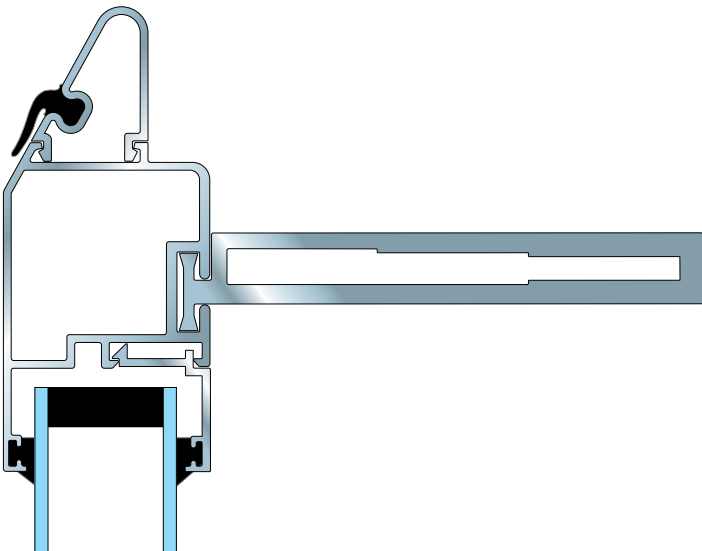

Door panel length L	Profile	Quantity of profiles
< 4500	-	-
4501 - 6500	AI 60	on each door panel
> 5000	AI 100	for door with wicket door on 4th panel
> 6501	AI 100	on each door panel

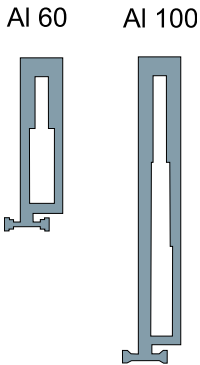

WINDOWS



Types of windows

Rectangular narrow

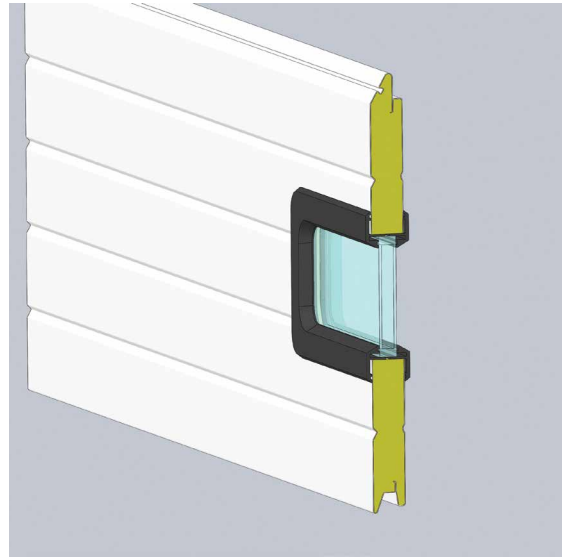
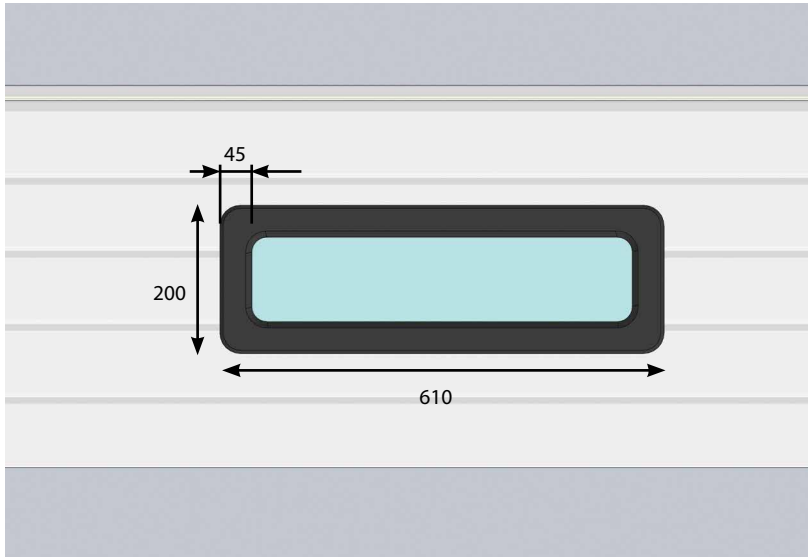

Rectangular

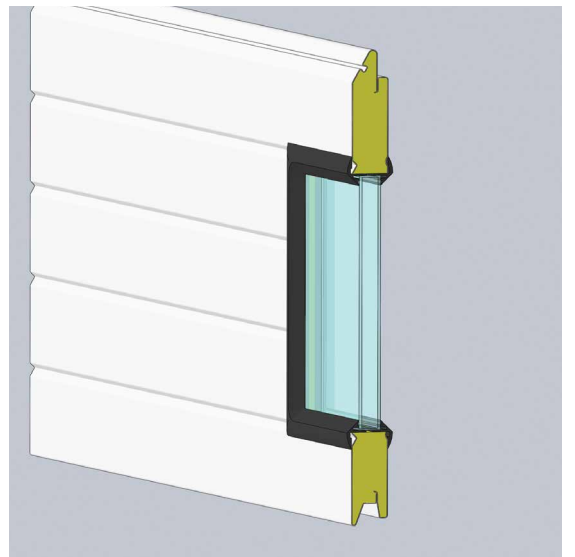
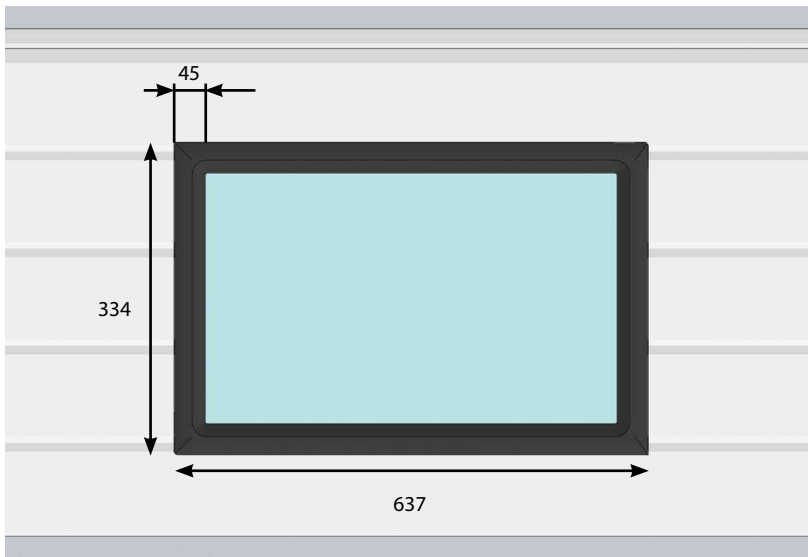

Oval

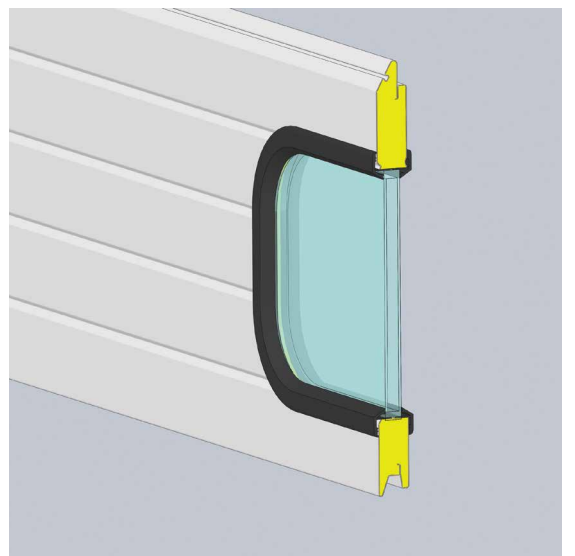
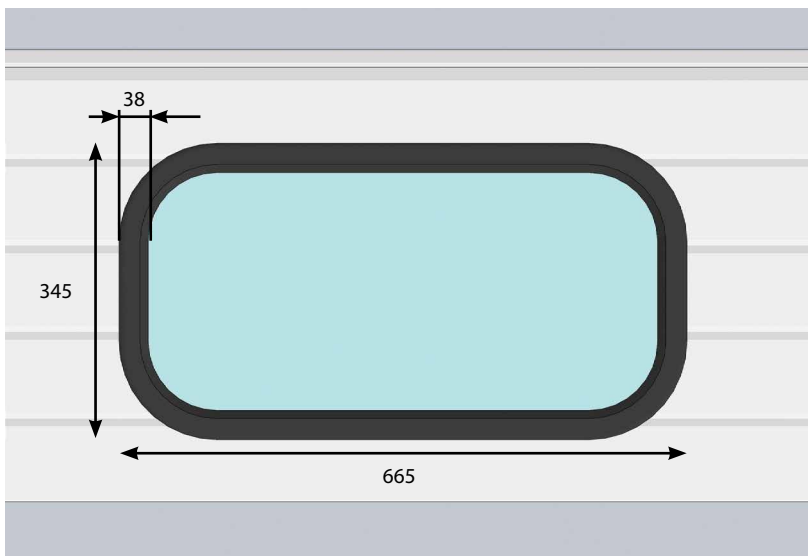

WICKET DOOR



WICKET DOOR

External view

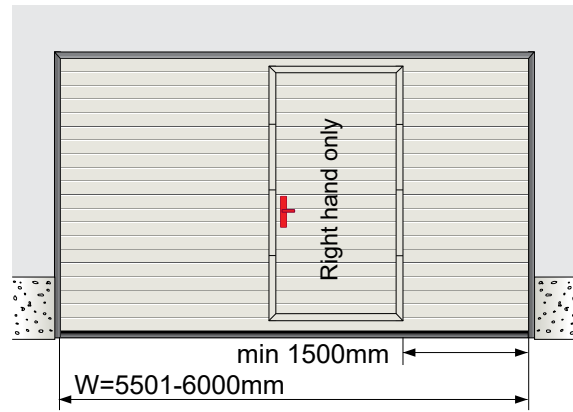
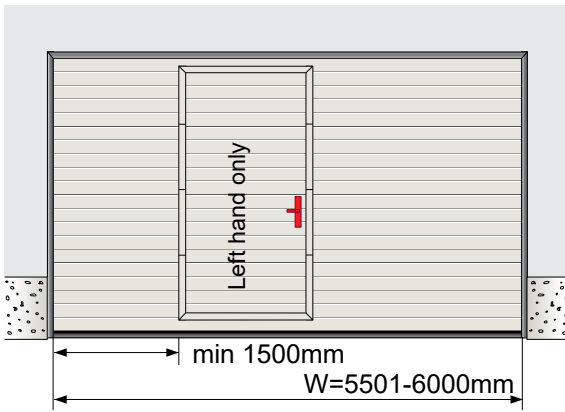
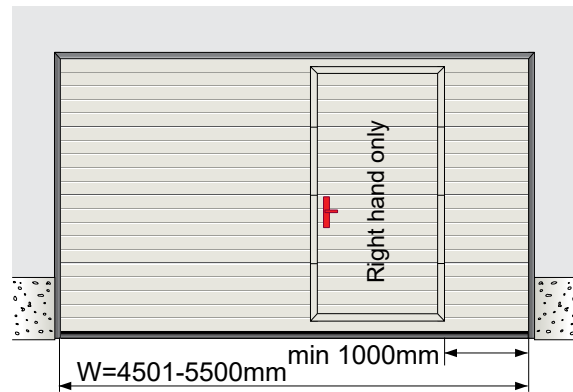
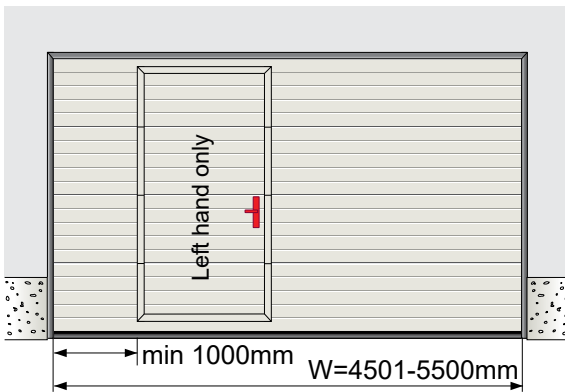
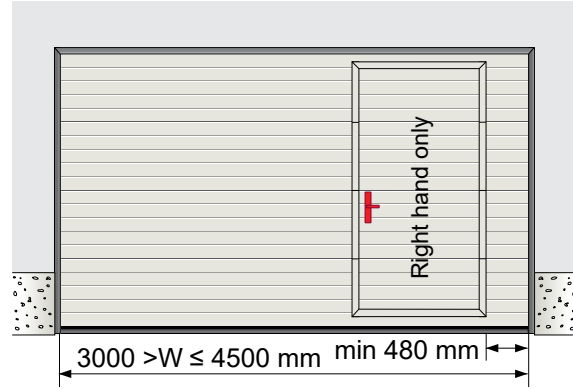
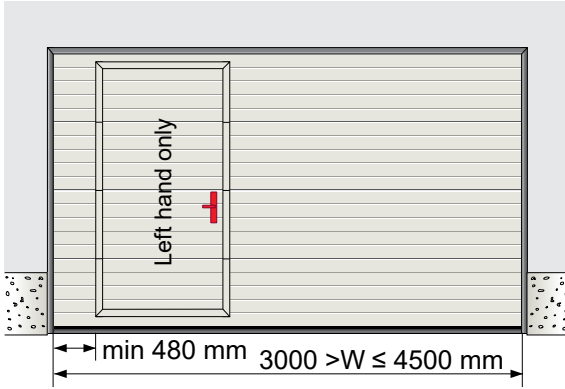

⚠ Handle side (L/R) maybe chosen when the wicket door is in the middle

⚠ Wicket door with higher threshold

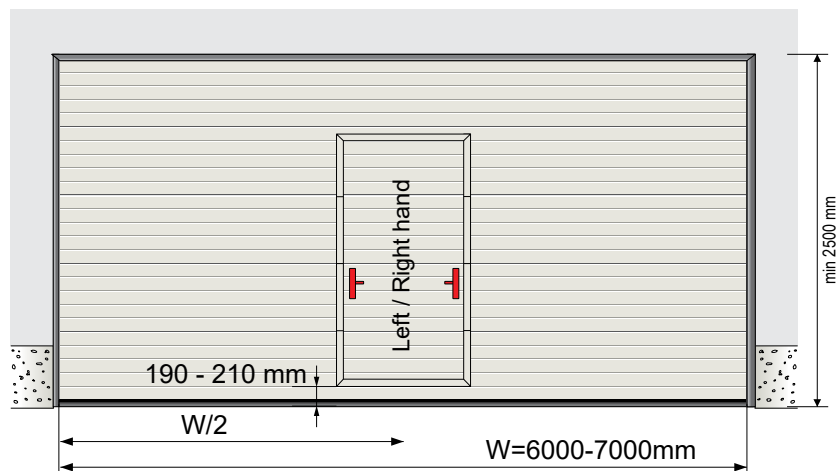
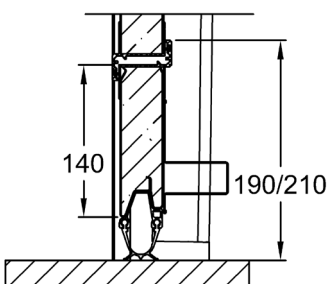

WICKET DOOR

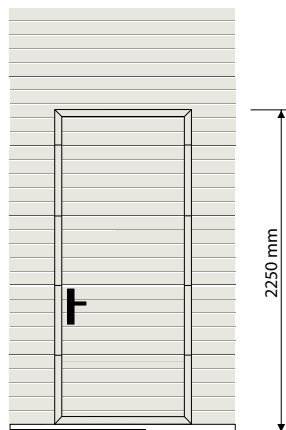
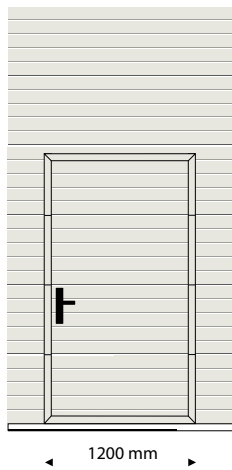
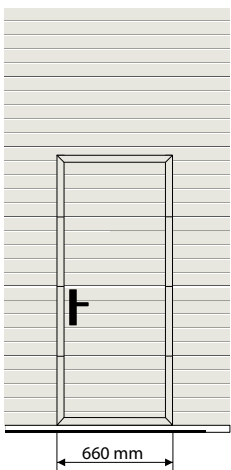
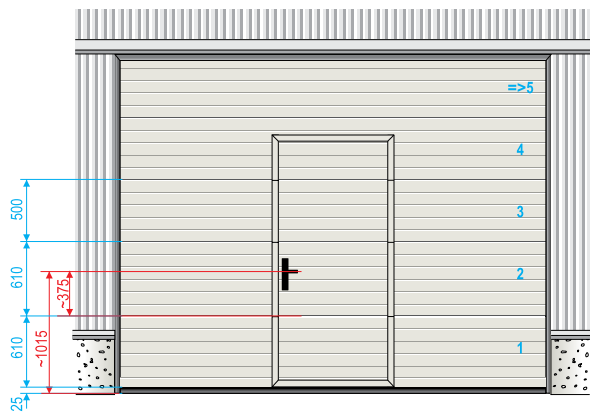
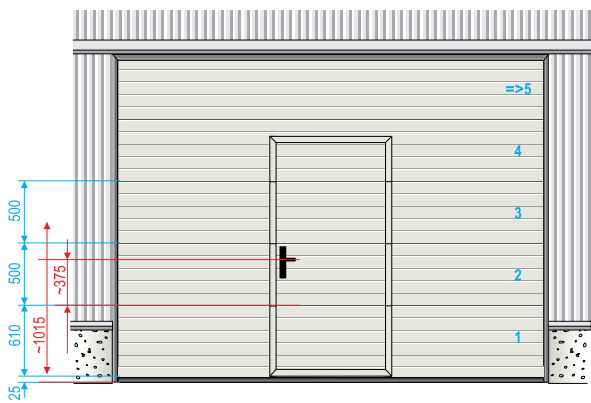
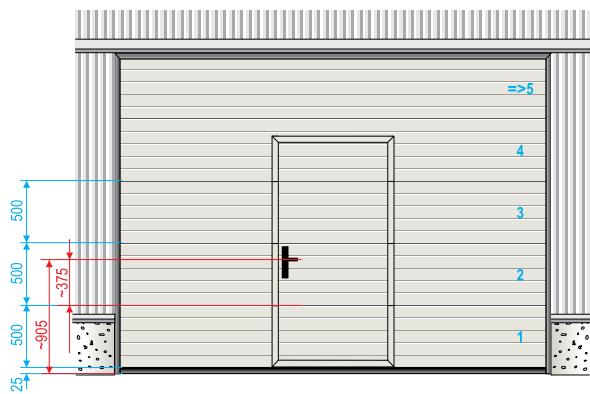
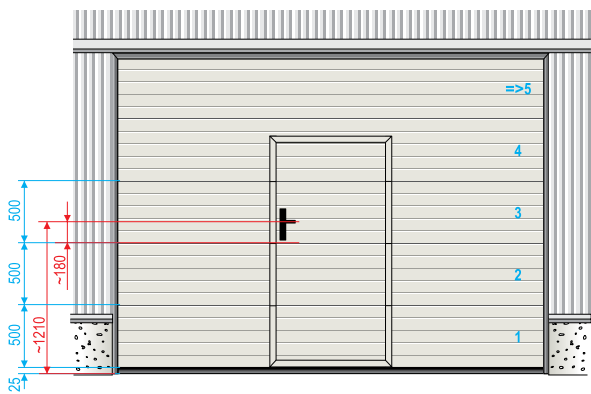
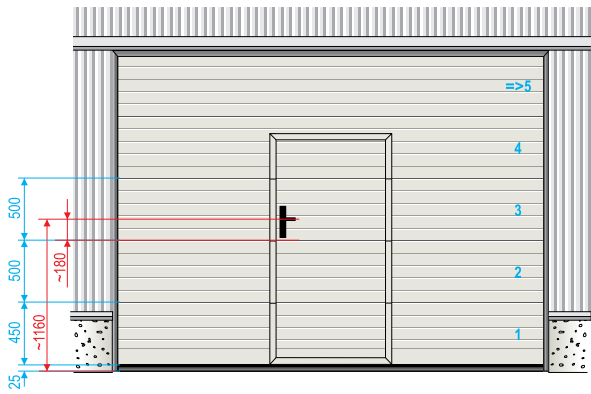

Consult factory for oversized doors

THRESHOLD TYPES

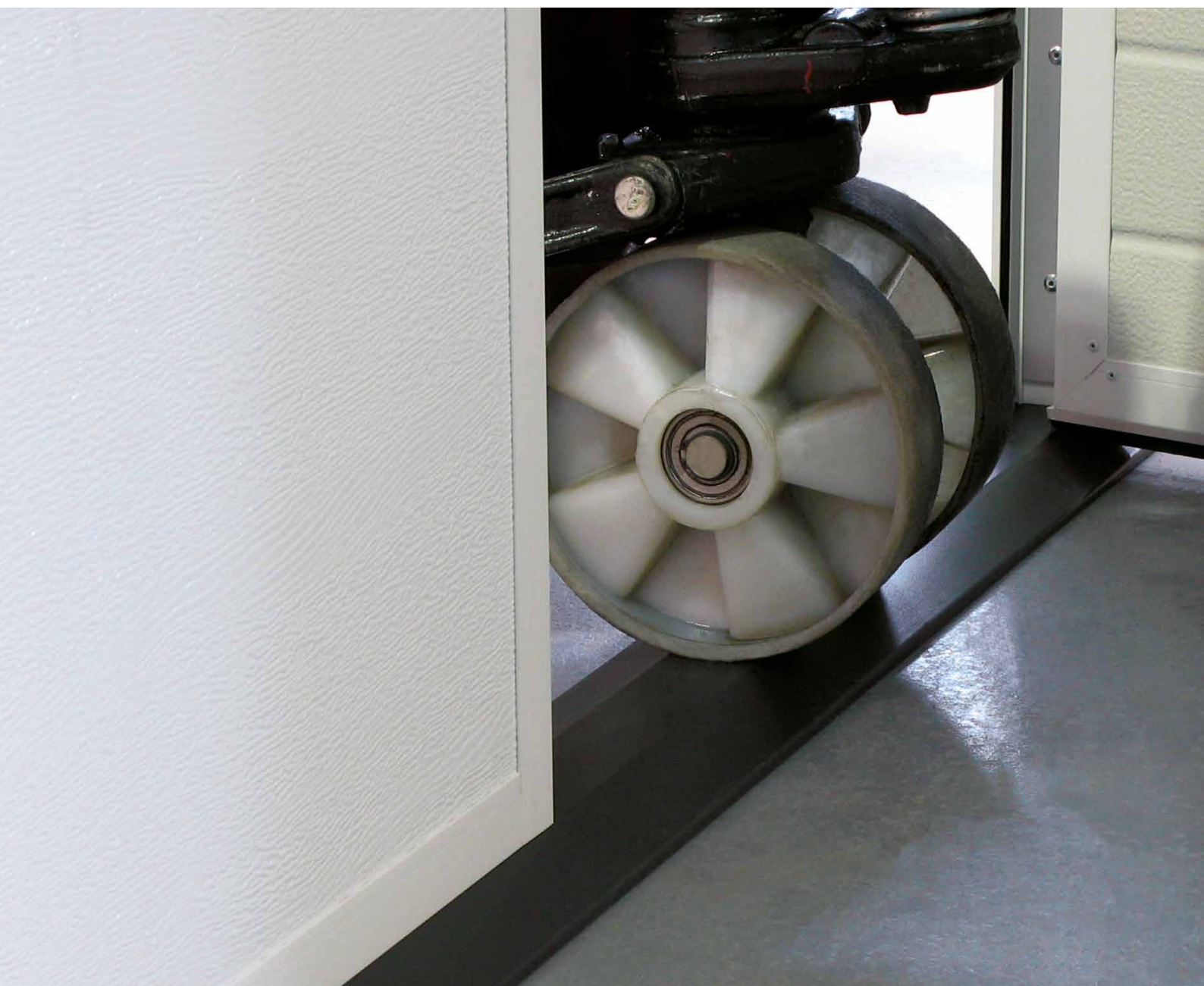

STANDARD THRESHOLD

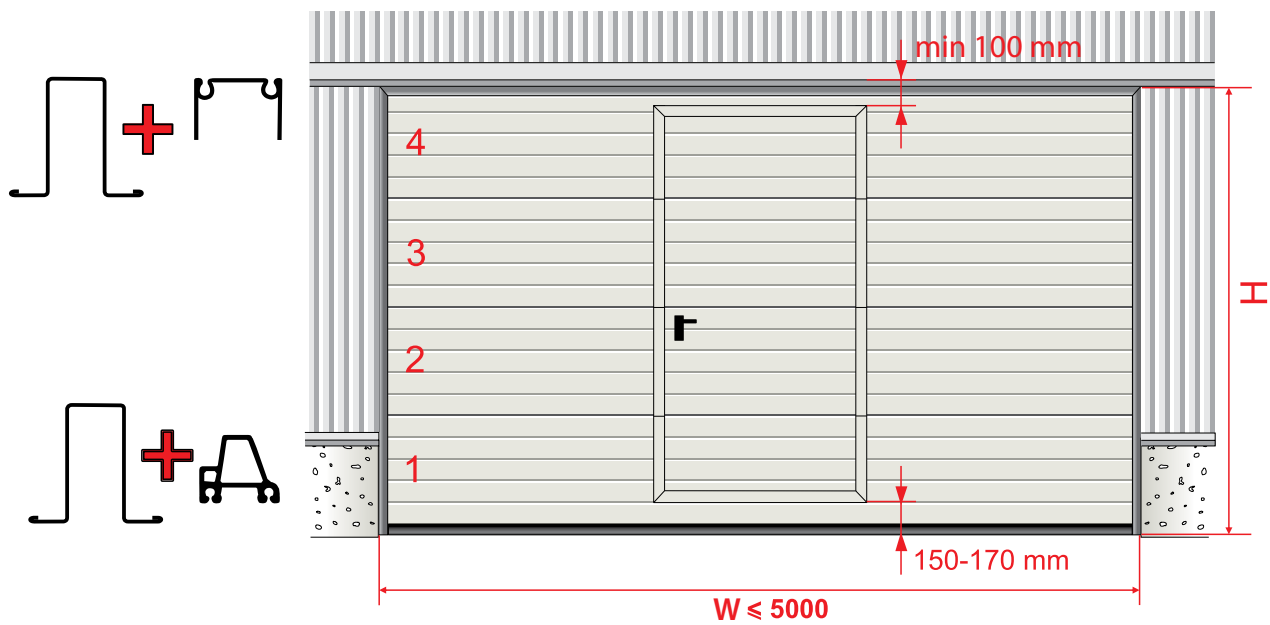

Usable with opto or pneumo safety edge.

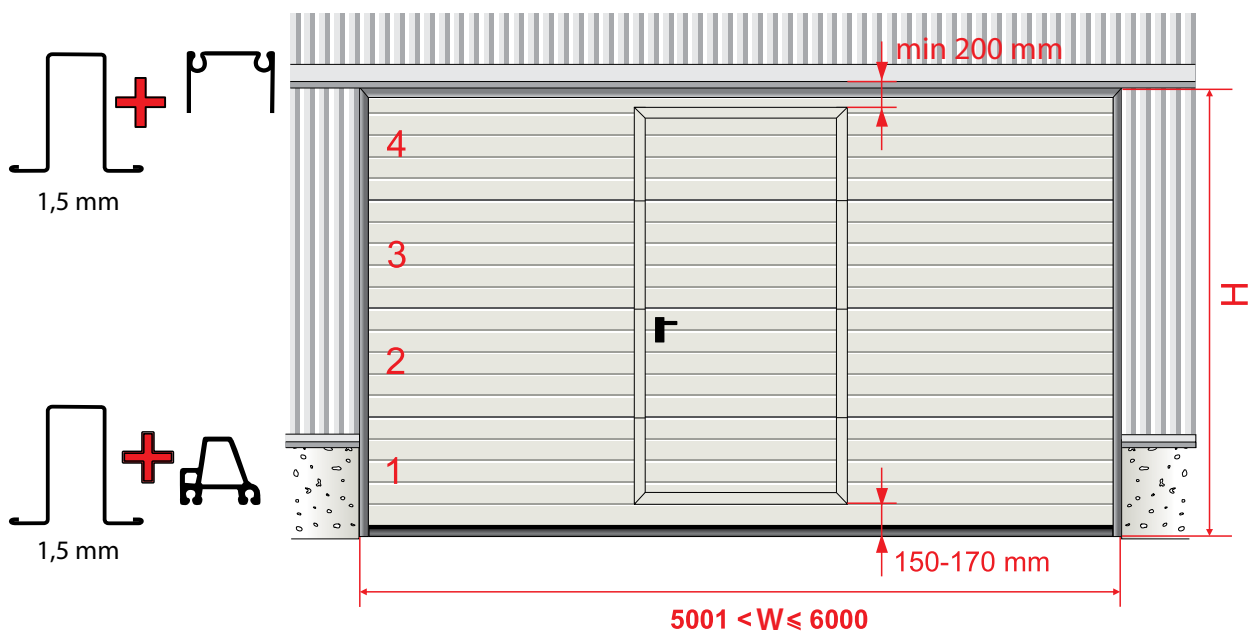

$W > 6001$ - on request

LOW THRESHOLD

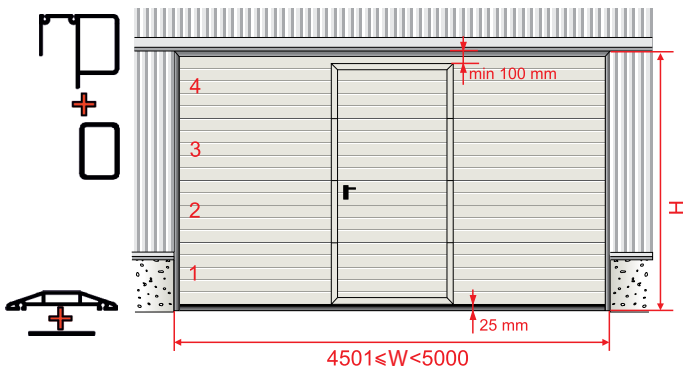
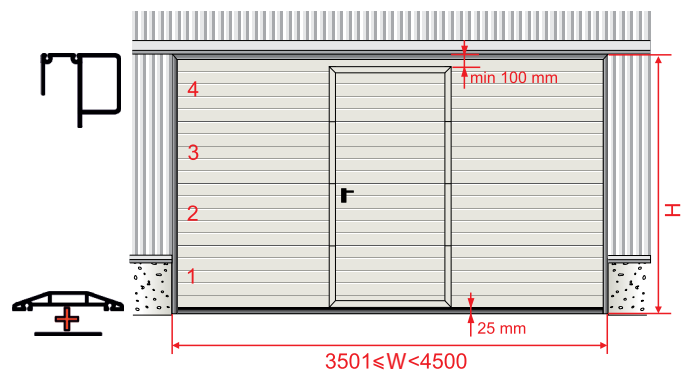
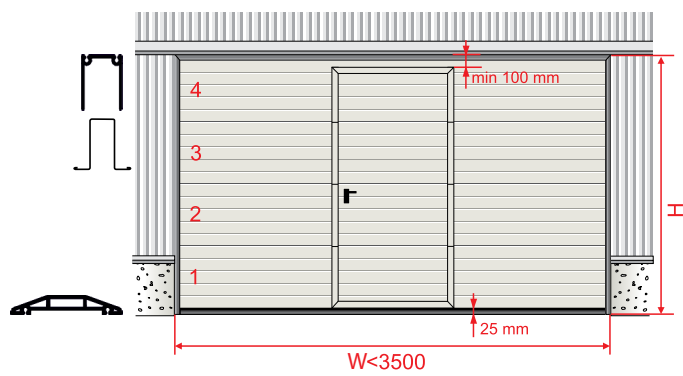
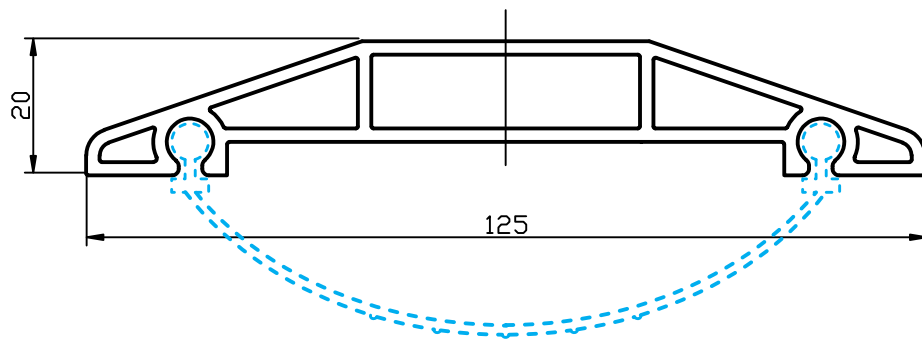

$W \geq 5001$ - on request

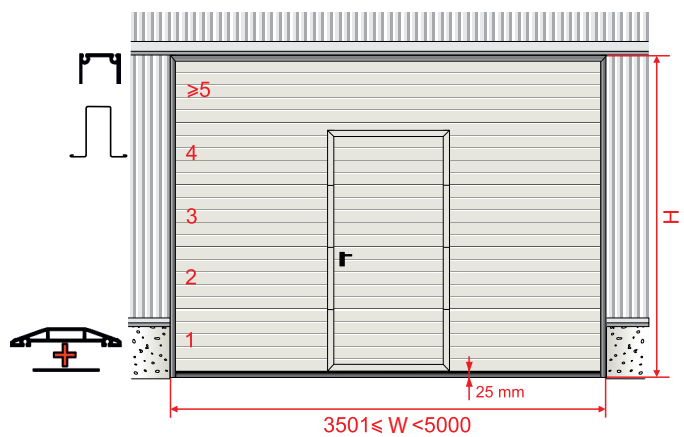
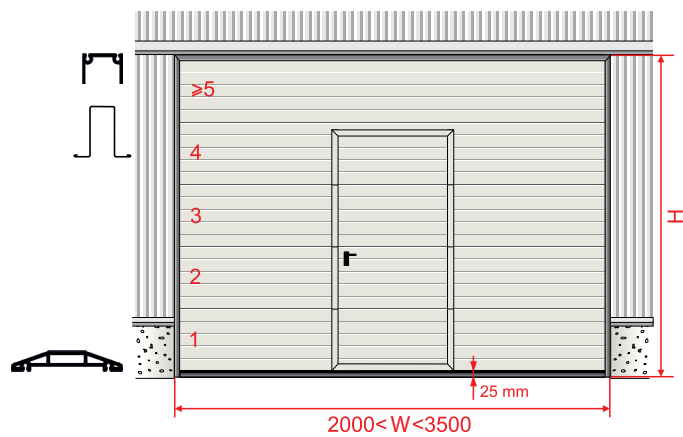

SIDE-HINGED DOORS

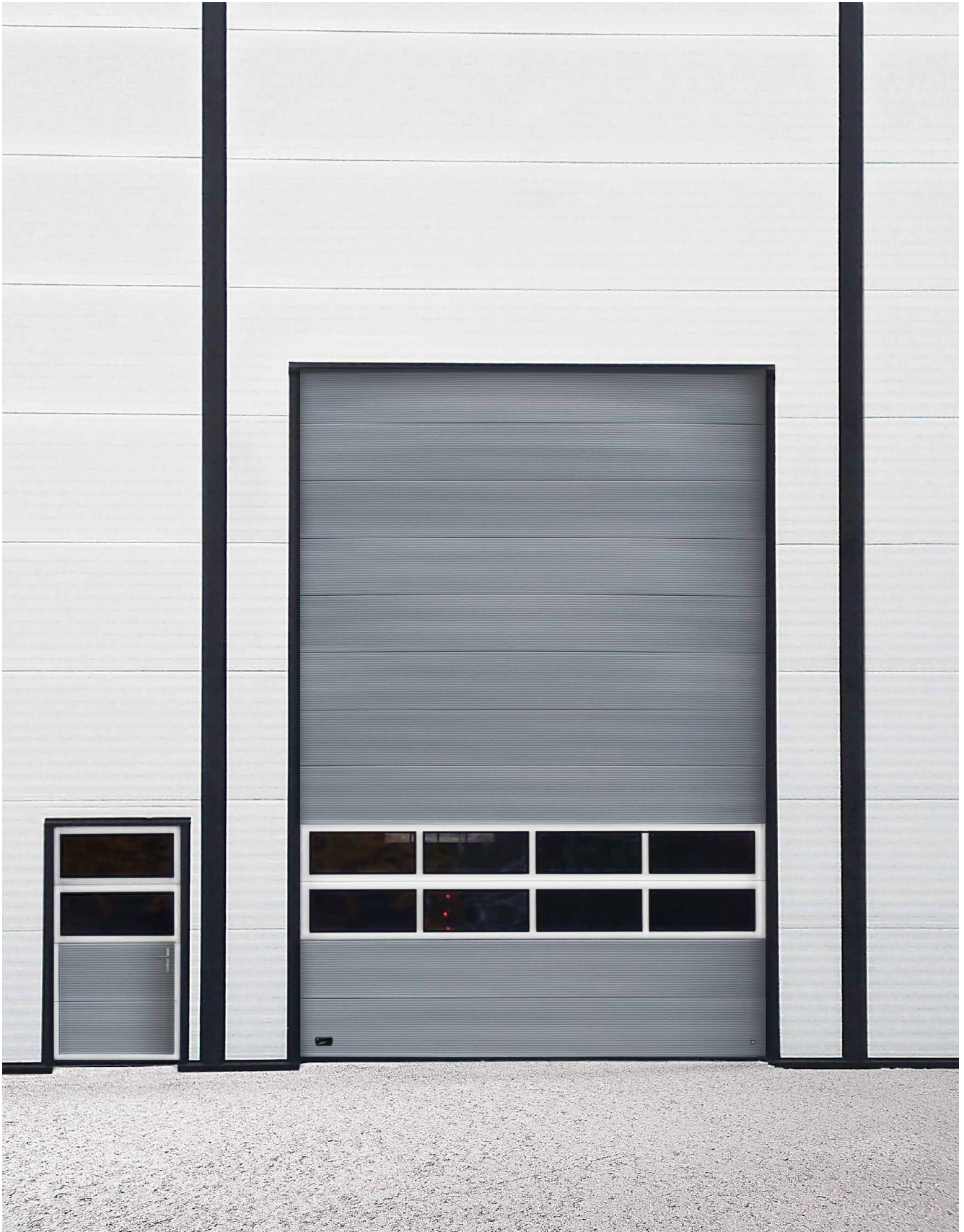

SIDE DOOR (SH1)

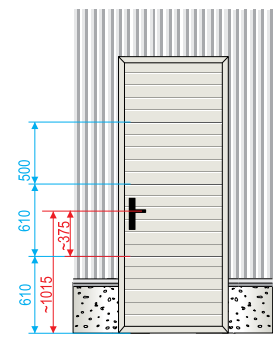
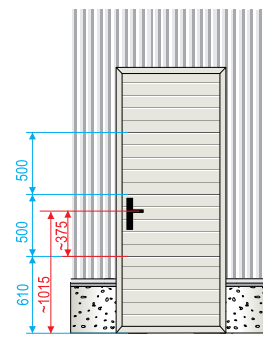
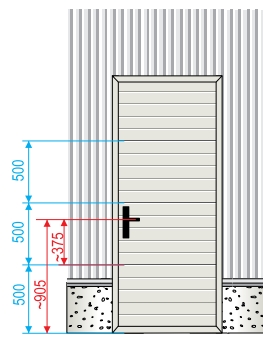
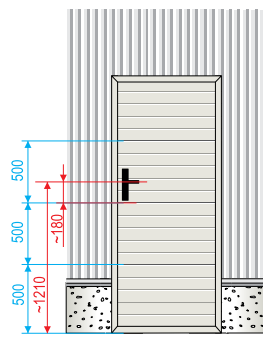
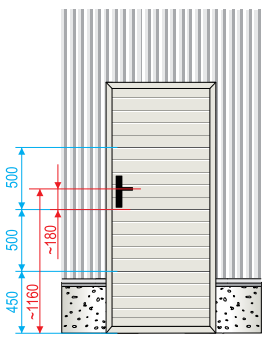
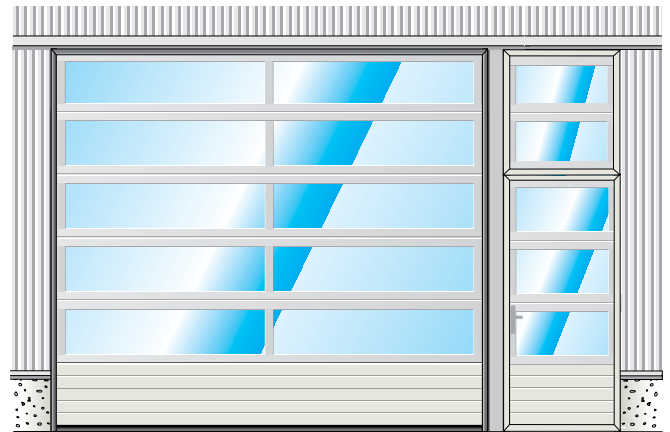
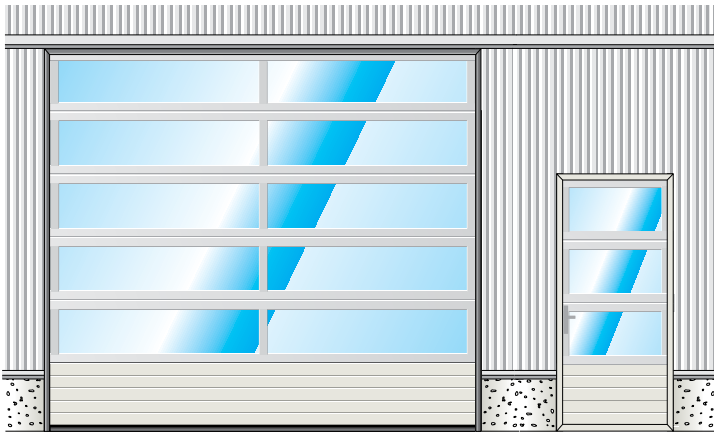
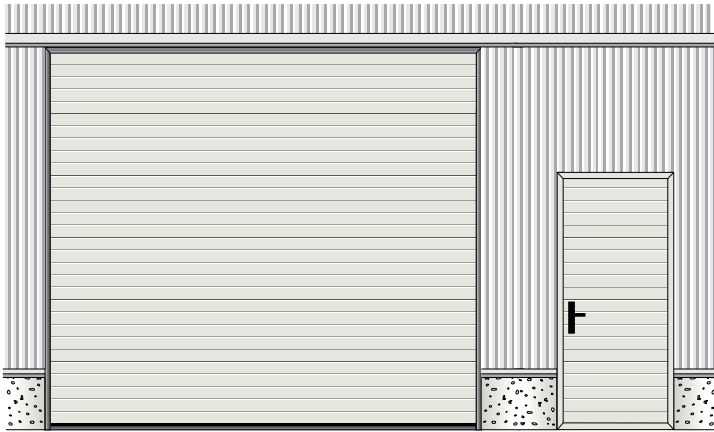

Side door critical dimensions

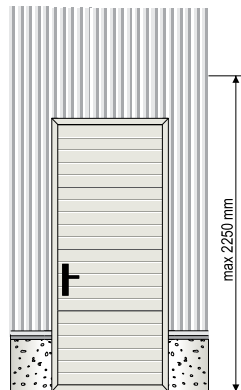
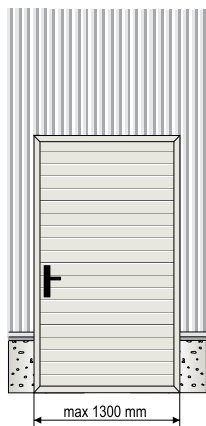
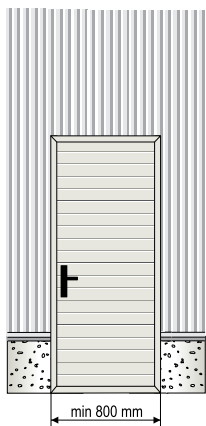

Consult factory for oversized doors

SIDE DOOR (SH1)

Side doors fitting and opening options

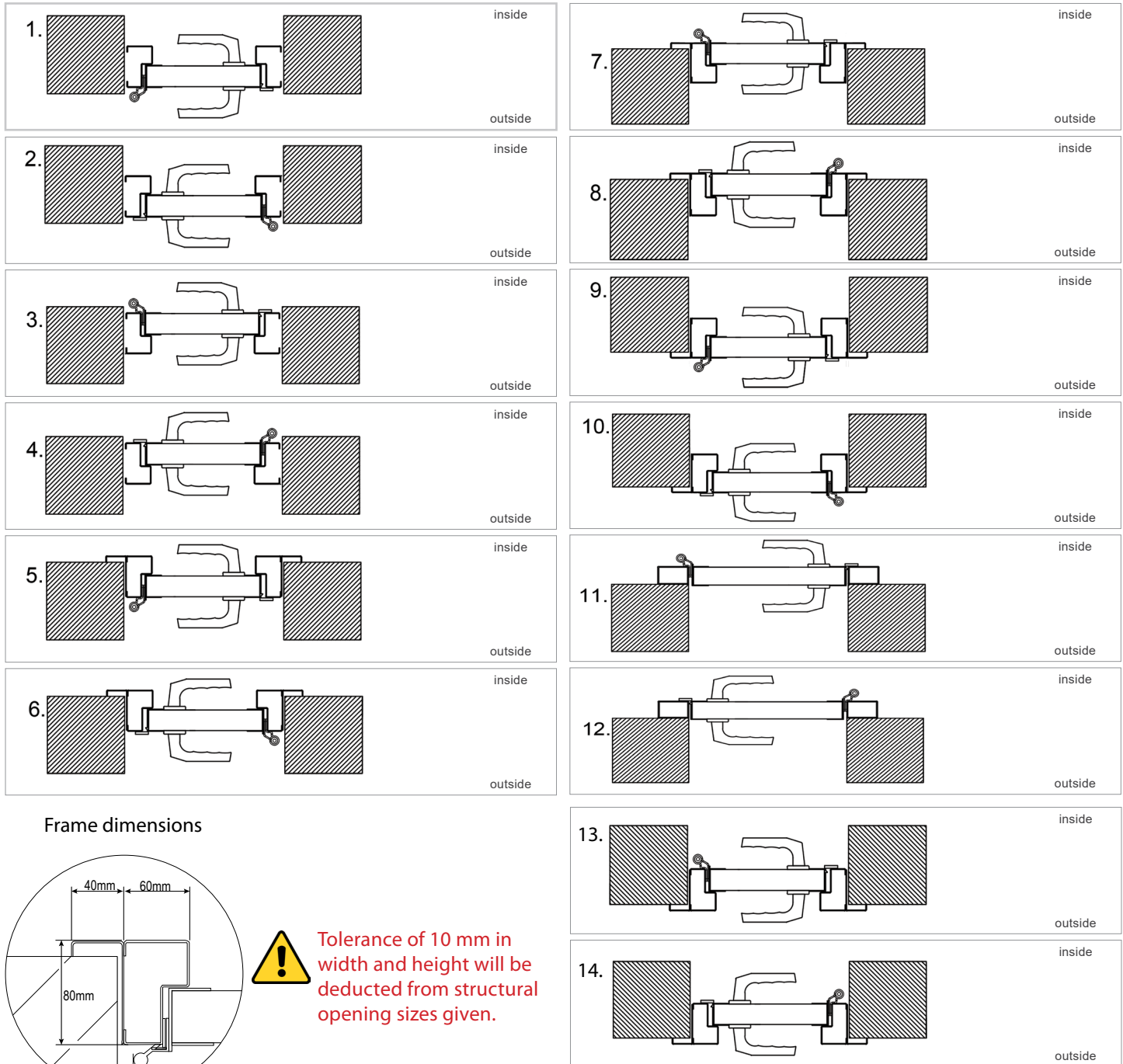

Frame dimensions

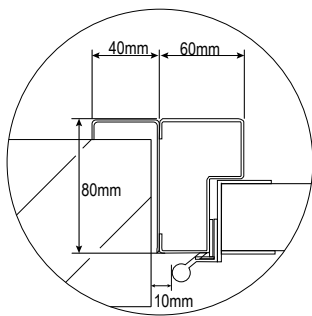

Tolerance of 10 mm in width and height will be deducted from structural opening sizes given.

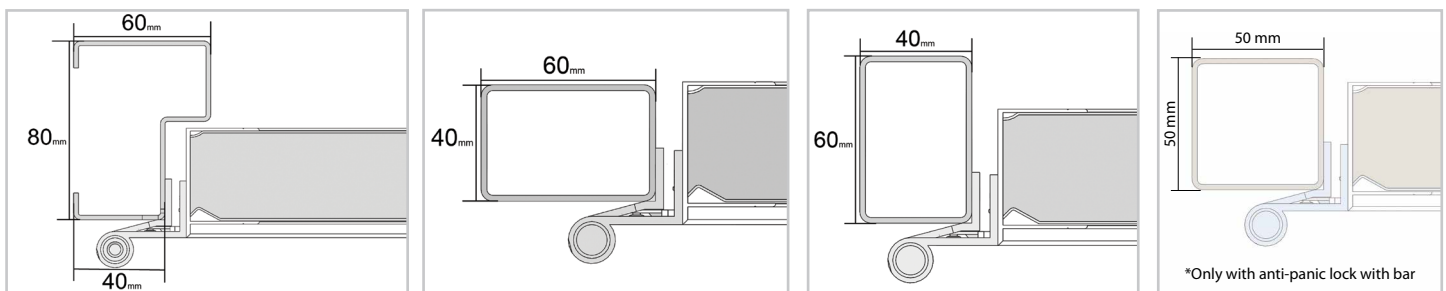

SIDE DOOR (SH1)

Side doors threshold types

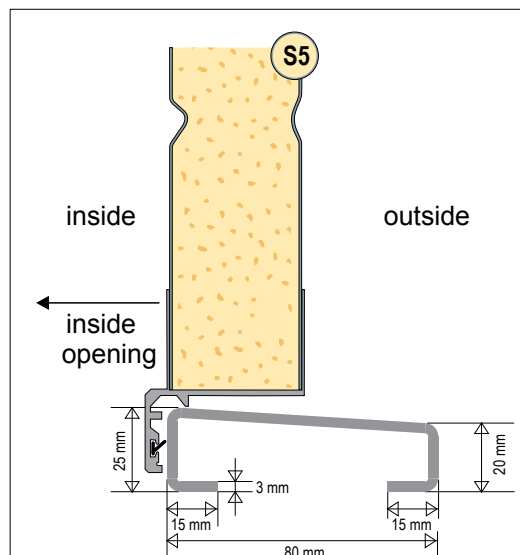
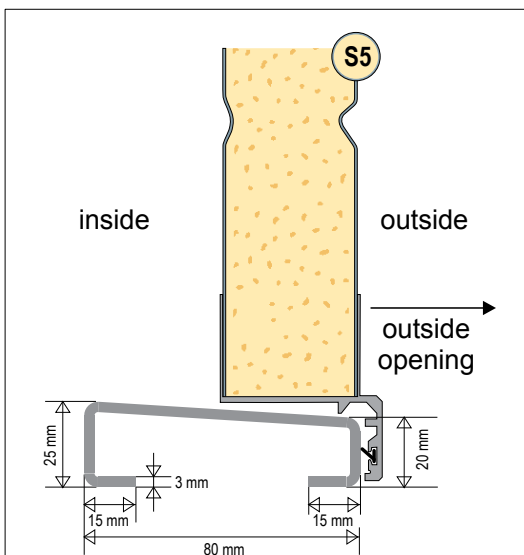
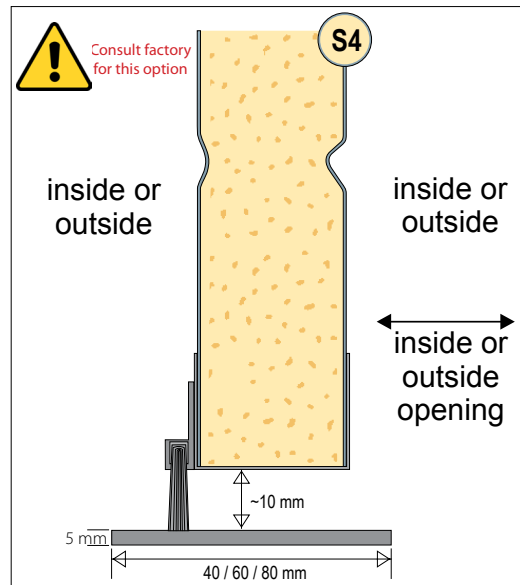
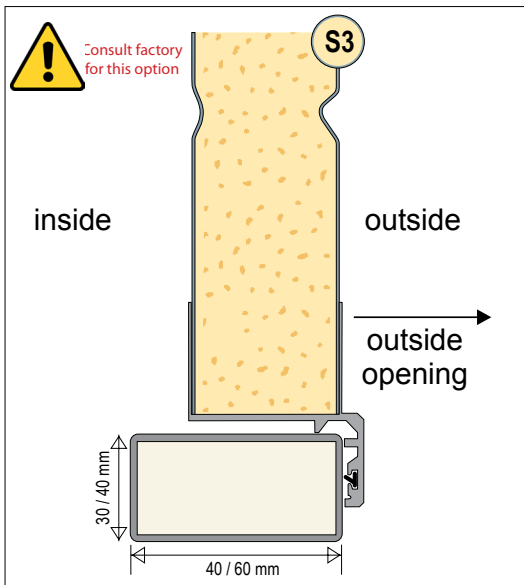
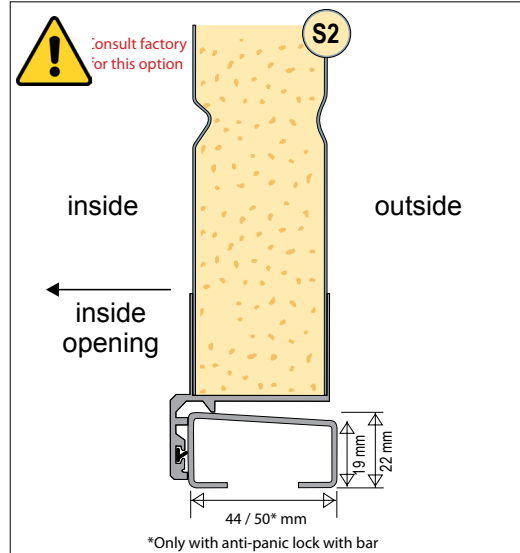
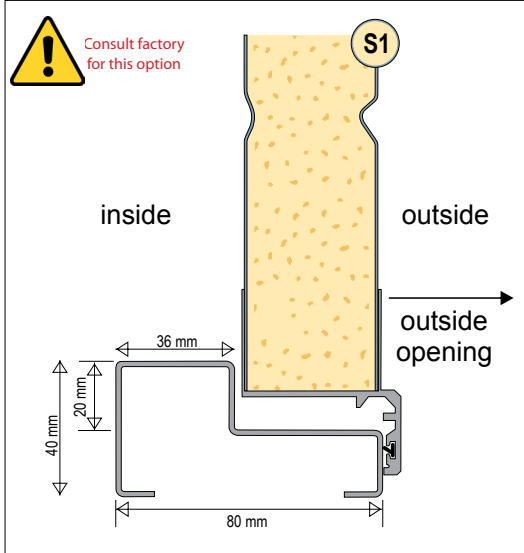

DOUBLE HINGED DOOR (SH2)

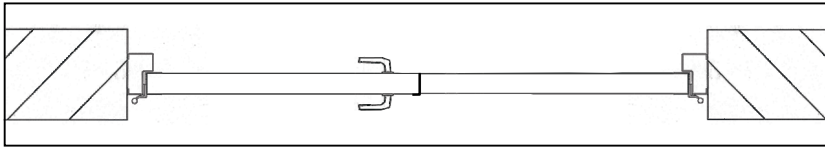
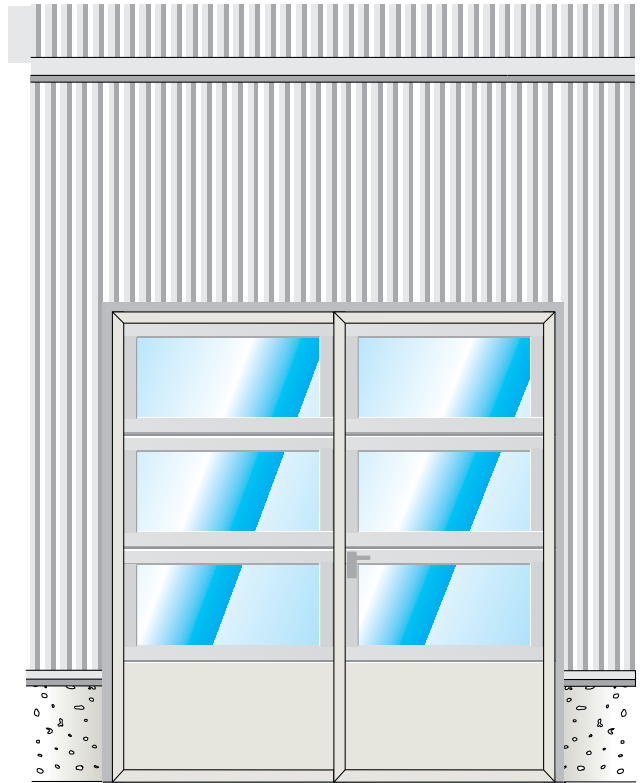
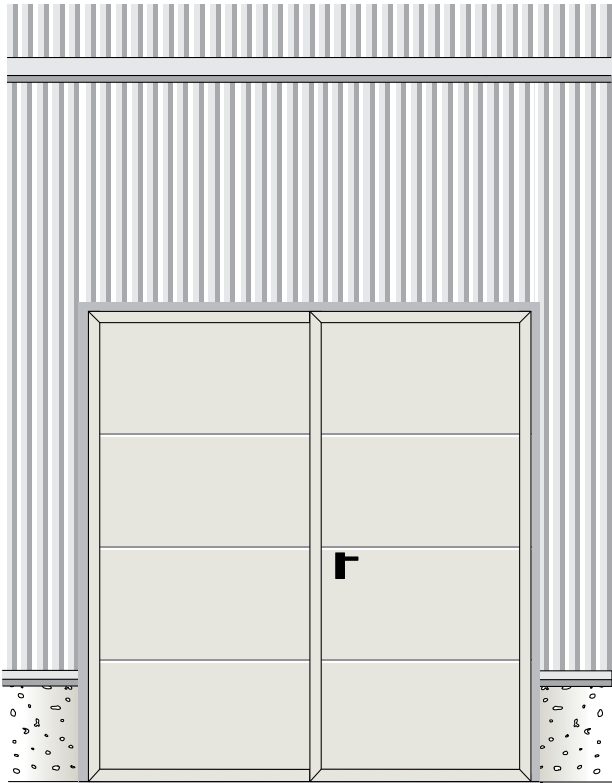

Two leaf doors are recommended when the opening is wider than 1300 mm.

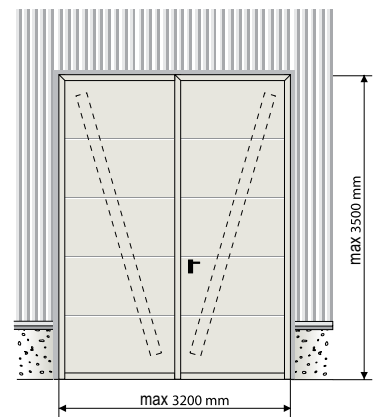
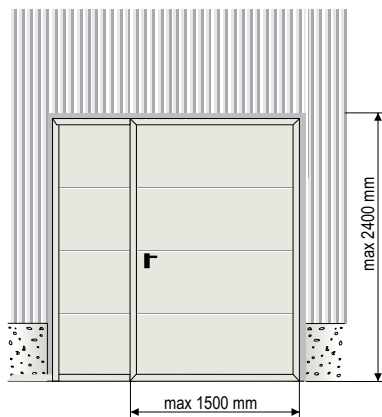
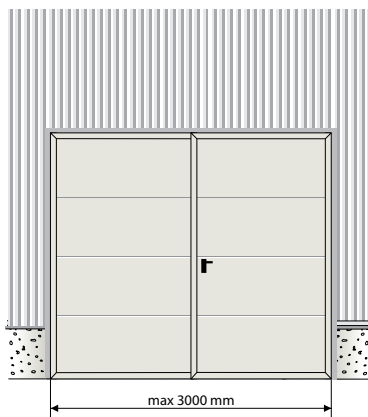
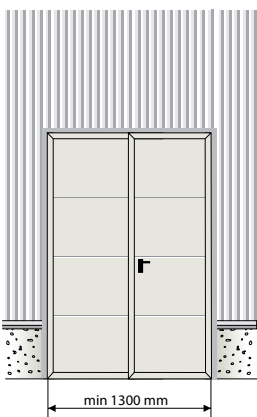

Consult factory for oversized doors

DOUBLE HINGED DOOR (SH2)

SH2 opening and handling options

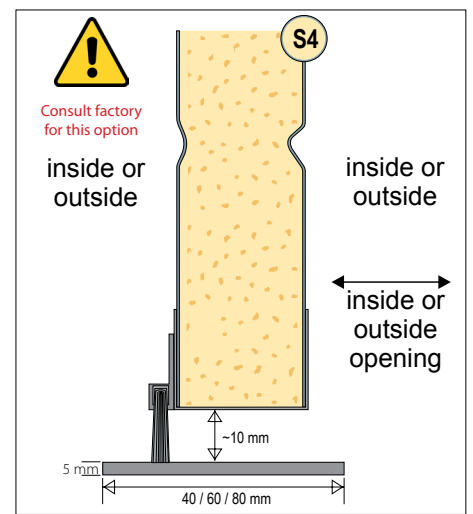
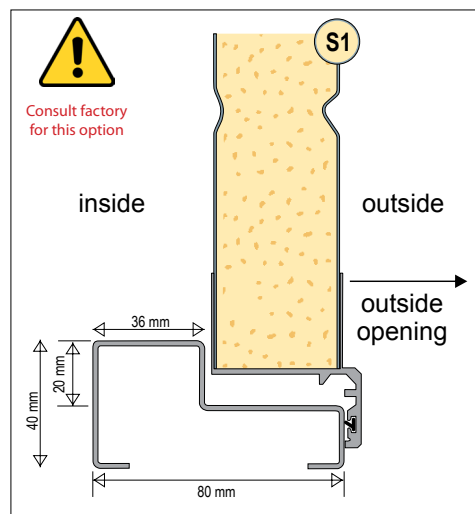
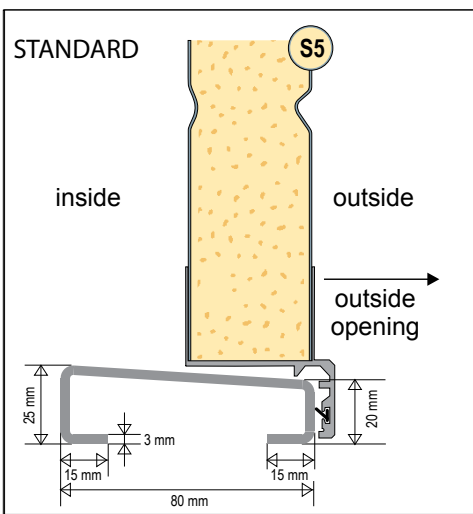
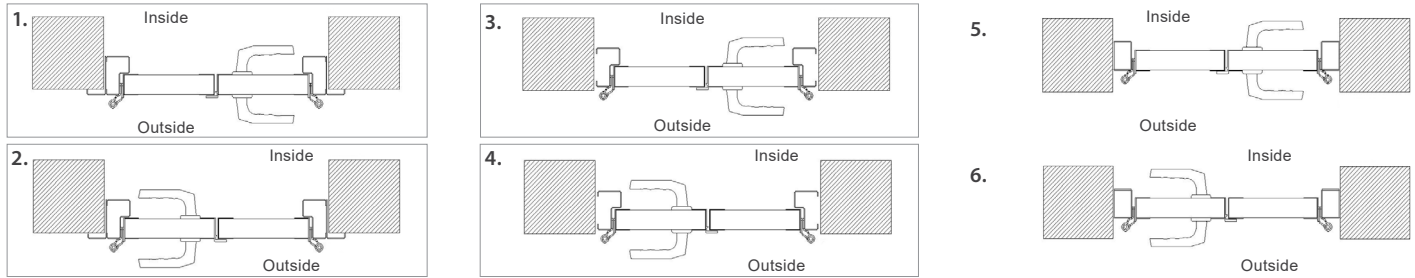

Locking options and door stays

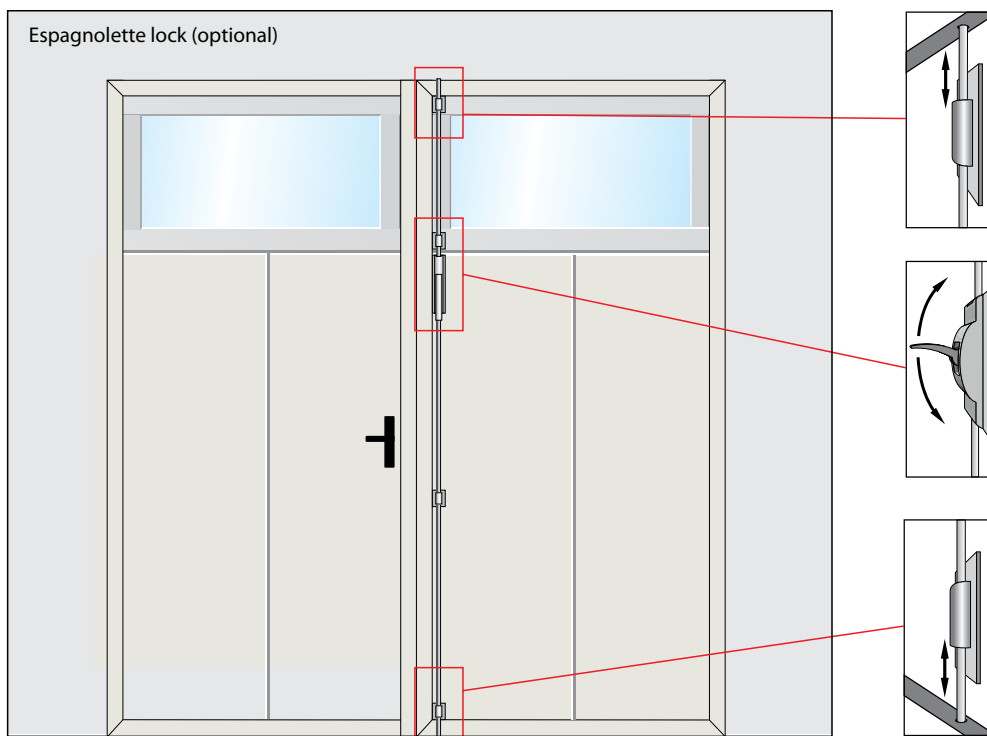

OPERATORS



OPERATORS' FIXING OPTIONS

Side fixing

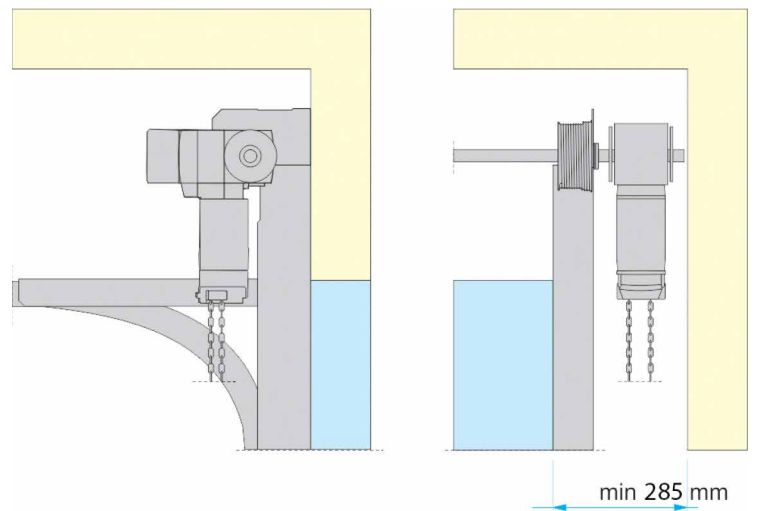
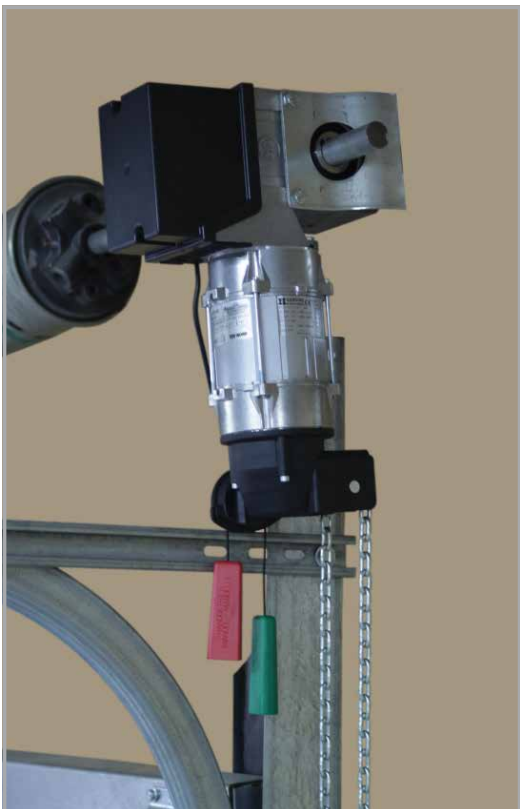
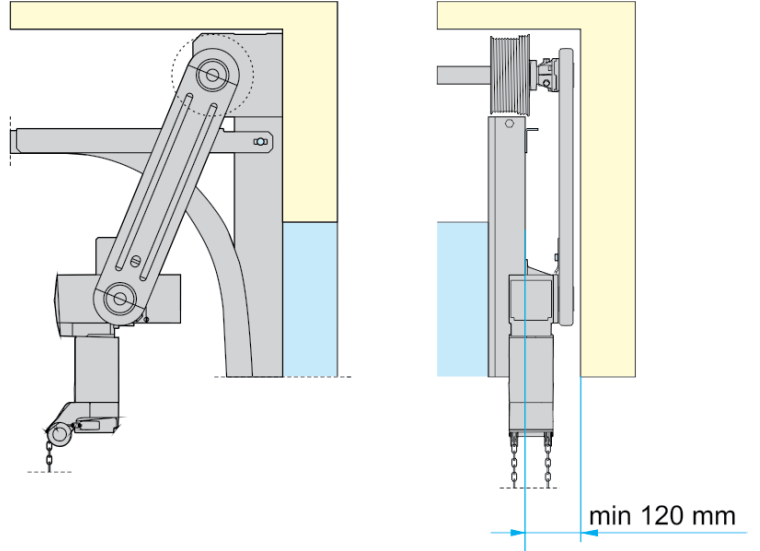

OPERATORS' FIXING OPTIONS

Centre fixing

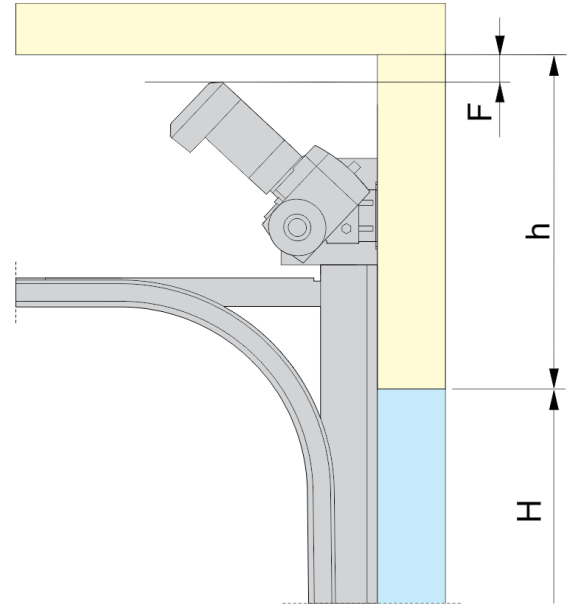
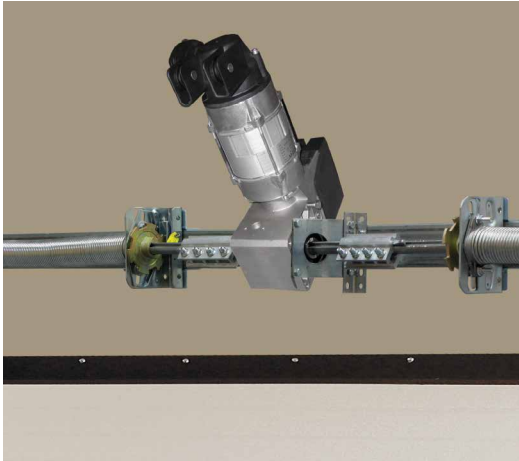

Door height	h	F
$H \leq 3000$	580	50
$3000 < H \leq 5030$	620	50
$5030 < H \leq 6000$	700	50
$H > 6000$ on request		

Chain hoist

